

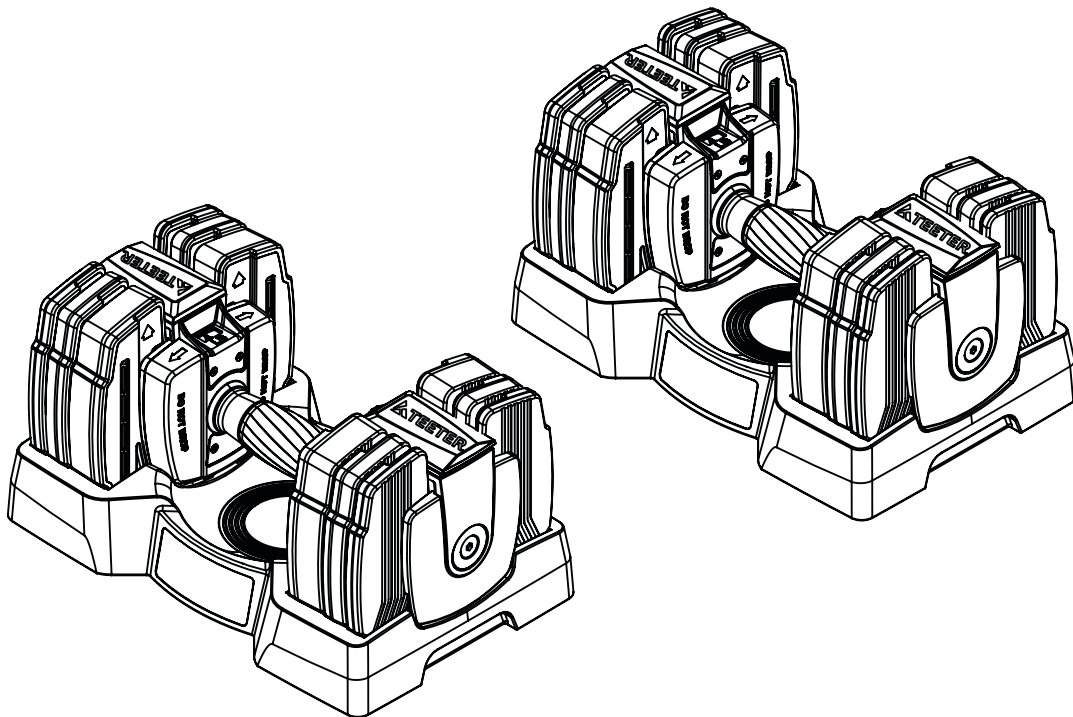

GET STARTED

User Guide

ProFlex™ 432 Adjustable Dumbbells



* Specifications may vary from this image and are subject to change without notice.

WELCOME TO THE TEETER FAMILY

Congratulations on your purchase of Teeter ProFlex™ 432 Adjustable Dumbbells! In order to utilize this product to its fullest extent, it is critical that you follow, read, and fully understand this User Guide. ProFlex 432 Dumbbells are designed as multiple user equipment for home use, intended to provide resistance training for adults, with convenient adjustability in 4 lb increments from 4-32 lb.

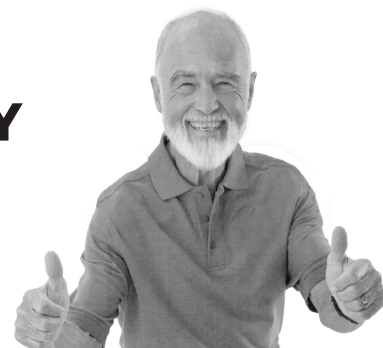

“ I created Teeter so people could live healthier and more active lives. ”

-Roger Teeter



CONTACT

CUSTOMER SERVICE

If you have any questions concerning assembly or if any parts are missing, DO NOT RETURN THE ITEM TO THE STORE OR CONTACT THE RETAILER. Our dedicated product service experts can help! Contact Teeter Customer Service at **800-847-0143**, or via online forms or Live Chat at **teeter.com**.



FULL PRODUCT

WARRANTY

Trust Teeter for unmatched quality and performance, backed by our industry-leading warranty coverage. To register your product warranty, go to **teeter.com/Support/Warranty-Registration**

TABLE OF CONTENTS

Important Safety Instructions	1
A Guide to Your Dumbbells	2
Safety Warning Labels & Product Specifications	3
How to Use	4
Testing the Locking Mechanism	5
Troubleshooting & Maintenance	7
Warranty Terms & Registration	8

BEFORE YOU BEGIN: Review all steps before beginning assembly and read all precautions before using the Teeter ProFlex 432 Dumbbells. Carefully adhere to the User Guide to help ensure safety and product integrity.

IMPORTANT SAFETY INSTRUCTIONS

READ ALL INSTRUCTIONS BEFORE USING THE TEETER PROFLEX DUMBBELLS

WARNING

FAILURE TO FOLLOW INSTRUCTIONS AND WARNINGS COULD RESULT IN SERIOUS INJURY OR DEATH.

To reduce the risk of injury:

- Be certain to read and understand all of these instructions. Review all other accompanying documents and register your product with Teeter. Always inspect the dumbbells before using. It is your responsibility to familiarize yourself with the proper use of this equipment. Weight lifting has inherent risks, such as the weights falling on your head or body, finger pinching, or equipment failure. To minimize these risks, follow these instructions closely and inspect the dumbbell function often. It is the responsibility of the owner to ensure that all users of the product are fully informed about the proper use of the equipment and all safety precautions.
- **DO NOT** use equipment or begin any exercise program without a licensed physician's approval. If you feel faint, dizzy, short of breath or unwell, immediately stop using the product and consult your physician.
- **DO NOT** allow children to use or be near the equipment. Teenagers under 18 must always have parental supervision and instruction on proper use of the equipment.
- **ALWAYS** allow enough free space around the equipment for safe operation. Keep children, bystanders and pets away when in use.
- **ALWAYS** maintain a monthly test schedule to ensure the locking mechanism is working properly by following the testing guidelines within this User Guide.
- **DO NOT** attempt to force rotation of the Weight Selector Grip when the dumbbell is removed from its base.
- **DO NOT** allow the dumbbells to drop to the ground, clang together or hit solid objects forcefully.
- **DO NOT** stand on, climb or place bodyweight on dumbbells. Use the dumbbells for their intended purpose only.
- **DO NOT** attempt to disassemble dumbbells or Base. This product is not user serviceable. Contact Teeter Customer Service for repair or replacement.
- **DO NOT** drop or insert any object into any opening. Keep body parts, hair, loose clothing and jewelry clear of all moving parts.
- **DO NOT** use in any commercial, rental or institutional setting. This product is intended for indoor, home-use only.
- **DO NOT** store outdoors.
- **DO NOT** operate equipment while under the influence of drugs, alcohol, or medication that may cause drowsiness or disorientation.
- **ALWAYS** inspect the equipment prior to use. Replace defective components immediately and/or keep the equipment out of use until repair.
- **ALWAYS** position equipment on a solid, level surface.
- Refer to additional warning notices posted on the equipment. If a product label or User Guide should become lost, damaged or illegible, contact Customer Service at 800-847-0143 for a replacement.

SAVE THESE INSTRUCTIONS

A GUIDE TO YOUR PROFLEX 432 DUMBBELLS

Before reading further, study the drawing below to familiarize yourself with the important components of your Teeter ProFlex Dumbbells.

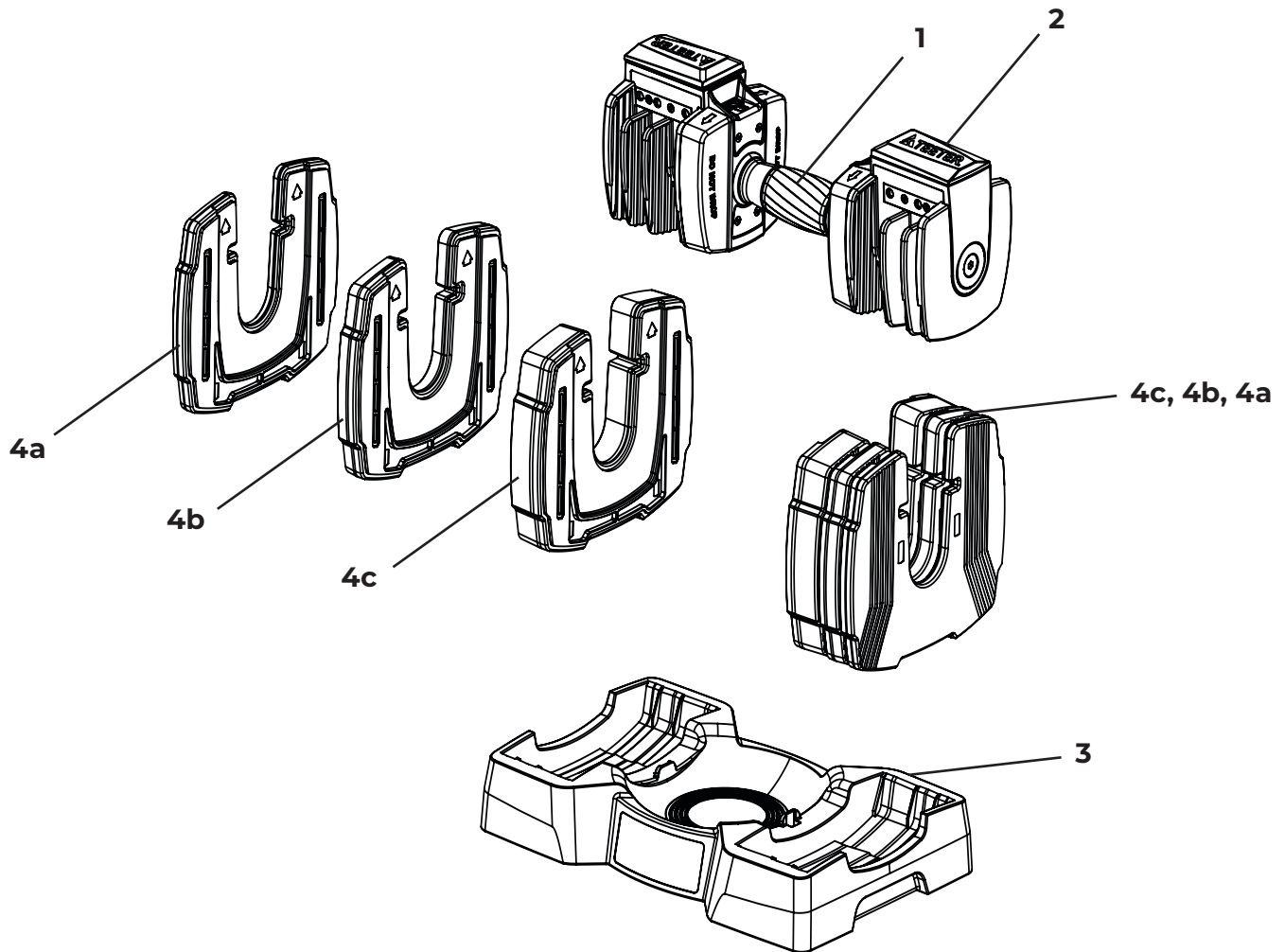

Parts & Components

- | | | | |
|----------|---------------|-----------|----------------|
| 1 | Selector Grip | 4 | Weight Plates |
| 2 | Dumbbell | 4a | 2 lb (0.91 kg) |
| 3 | Base | 4b | 4 lb (1.81 kg) |
| | | 4c | 8 lb (3.63 kg) |

SAFETY WARNING LABELS & PRODUCT SPECIFICATIONS

Important: Please review all labels and supporting materials before using your dumbbells.

This drawing indicates the locations of the warning labels found on your product. If a label is missing, illegible or is removed, contact Teeter Customer Service to request a complimentary replacement label.

Note: Image and labels below not shown at actual size.

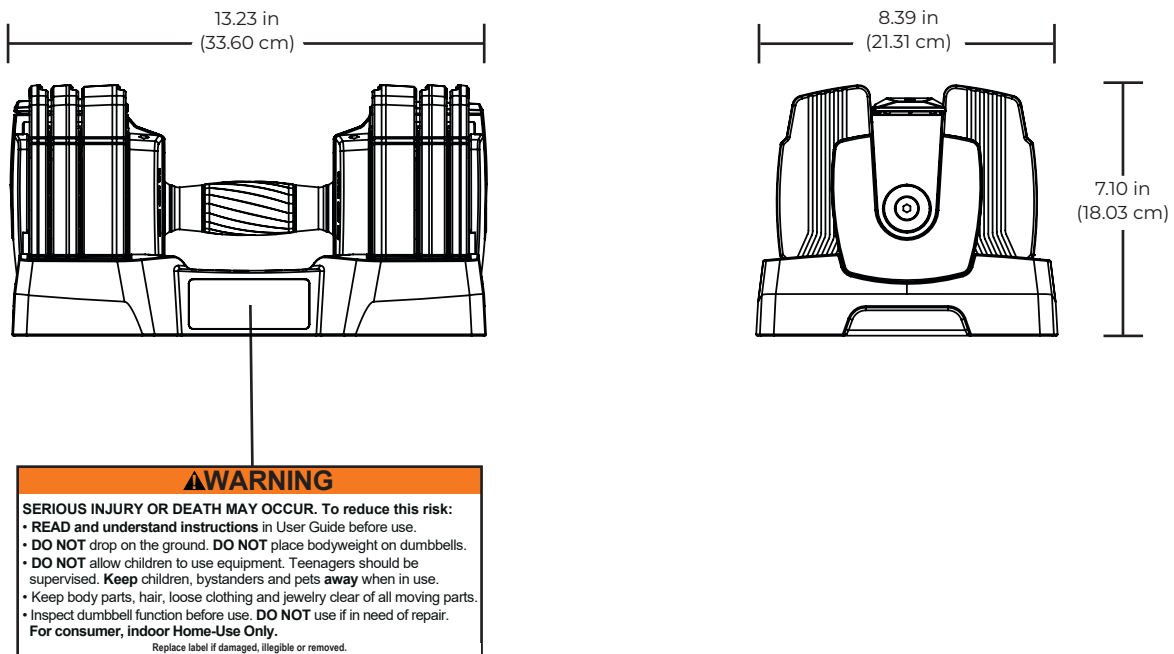

Dimensions: 13.23 x 8.39 x 7.10 in (33.60 x 21.31 x 18.03 cm)

Weight with Base (approx.): 35.9 lb (16.3 kg)

There are 8 weight increments:

4 lb (1.81 kg)	8 lb (3.63 kg)	12 lb (5.44 kg)	16 lb (7.26 kg)	20 lb (9.07 kg)	24 lb (10.89 kg)	28 lb (12.70 kg)	32 lb (14.51 kg)
-------------------	-------------------	--------------------	--------------------	--------------------	---------------------	---------------------	---------------------

*Exact weight values may vary due to manufacturing variances

Teeter ProFlex Dumbbells arrive fully assembled. Carefully follow removal instructions printed on the box. Be sure to inspect the product for damage prior to use.

HOW TO USE

⚠ WARNING

DO NOT drop or place bodyweight on the Dumbbells. This could damage the Weight Plates and/or locking mechanism, causing the Weight Plates to disengage from the Dumbbell. This can cause serious injury and will void the warranty.

To Operate:

Teeter ProFlex Dumbbells feature a locking mechanism that 1) secures the Weight Plates to the Dumbbell and 2) ensures proper alignment and attachment of the weights in the Base.

With a simple click of the Selector Grip, you can adjust your weight setting quickly and easily.

Figure 1: Grasp the Selector Grip and rotate in either direction to adjust the weight in 4 lb increments.

The rotation is perpetual, which means that the weight will return to 4 lb once you rotate past the maximum 32 lb setting.

A click will occur at each weight increment to indicate the weight has been properly selected and the plates have locked into place.

Figure 2: Remove the Dumbbell from the Base in a straight, vertical motion.

⚠ WARNING

Do not attempt to force rotation of the Selector Grip when the Dumbbell is removed from the Base.

Figure 3: Replace the Dumbbell into the Base gently in a straight, vertical motion, aligning the Dumbbell ends with the recessed part of the Base.



Figure 1



Figure 2



Figure 3

TESTING THE LOCKING MECHANISM

⚠ WARNING

Monthly testing must be performed to ensure proper function of the dumbbells. If testing reveals a malfunctioning locking mechanism, discontinue use immediately and contact Teeter customer service.



Figure 4



Figure 5



Figure 6



Figure 7



Figure 8

Testing the Weight Selector Grip

Routine testing of the Selector Grip is important to ensure your safety. Schedule weekly or monthly reminders to perform these tests:

Figure 4: With the Dumbbell in the Base, set the Selector Grip to 4 lb (1.8kg). At this setting, all Weight Plates will remain in the Base when the Dumbbell is removed.

Figure 5 & 6: Pick up the Dumbbell and check that all Weight Plates remain securely attached to the Base. Return the Dumbbell to the Base.

Figure 7: Rotate the Selector Grip to rest between two weight increments (i.e. to the space between 4 lb and 8 lb). There will be no click as the Selector Grip has not locked any Weight Plates onto the Dumbbell.

Figure 8: While the Selector Grip is in the improper setting, attempt to lift the Dumbbell - DO NOT exert too much force. The Dumbbell should not separate from the Base.

Repeat same testing process at all of the weight settings for both dumbbells.

TROUBLESHOOTING & MAINTENANCE

Troubleshooting

Figure 9: If the Weight Selector Grip will not turn while Dumbbell is in the Base, check that the Dumbbell is completely inserted into the Base. If the Dumbbell is askew or not entirely seated, the locking mechanism will not engage.



Figure 9

⚠ WARNING

Do not use excessive force in an attempt to turn the locked Selector Grip or damage may occur to the locking mechanism. If you are unable to troubleshoot a malfunctioning Selector Grip, discontinue use immediately and contact Teeter customer service.

Figure 10: If the Dumbbell will not go back in the Base, verify that the Weight Plates that are not selected are in their correct slots and have not been moved to different support slots. This could be blocking the Dumbbell from fitting back in the Base correctly.



Figure 10

Maintenance

The Teeter ProFlex 432 Dumbbells require minimal to no maintenance. Internal lubrication has already been applied and the Weight Plates are designed to function with very low friction.

If your dumbbells become soiled from use or accidental spills, wipe down using a slightly damp warm water rag with gentle soap. Remove excess soap with a damp rag and dry with a separate rag. **DO NOT** use any harsh chemicals, bleach, harsh detergents, or solvents on this product. This can damage the integrity of the materials, resulting in degradation of safety and performance.

⚠ ATTENTION

DO NOT attempt to self-service your ProFlex dumbbells.
DO NOT disassemble the Dumbbell or Base or manufacturer's warranty will be voided.
Contact Teeter customer service at 800-847-0143 for maintenance assistance.

The Teeter warranty set forth below and on Teeter's website applies to US and Canadian customers only. For international customers, please consult your local distributor for warranty information, which will vary depending on country.



FULL PRODUCT WARRANTY

During the period starting with the day of retail purchase and continuing for two (2) years, Teeter extends to the owner a repair and replacement warranty against manufacturing defects in materials and workmanship. Teeter will repair or replace any such defect and will pay the costs of all parts, labor and transportation. If a repair or replacement is not commercially practical or cannot timely be made, then Teeter will, at the original Purchaser's option, replace with a comparable product or refund the purchase price.

Handling and transportation costs related to product warranty service only are covered by this warranty. This warranty does not cover damage resulting from improper handling, assembly, or installation, repairs made by others, accident, misuse, or abuse. Under no circumstances shall Teeter, or any other party involved in the sale of this product, have any liability for incidental or consequential damage arising from breach of an express or implied warranty on any Teeter product.

EXCEPT AS SET FORTH ABOVE, NO WARRANTY IS GIVEN WITH RESPECT TO ANY TEETER PRODUCT, AND ALL EXPRESS WARRANTIES ARE DISCLAIMED. This warranty shall be governed by the laws of the State of Washington, USA. To the extent this warranty is found not to be enforceable, it shall be deemed revised to the extent necessary to make it enforceable. Any controversy or claim arising out of or relating to this warranty, its interpretation, or any alleged breach thereof, which cannot be amicably settled between Teeter and the owner within sixty (60) days of written notice by the aggrieved party to the other, shall be finally settled by arbitration submitted to three (3) arbitrators selected from the panels of the arbitrators of the American Arbitration Association located closest to Teeter's principal place of business.

Some states do not allow the exclusion of incidental or consequential damage from a warranty, so the above limitation or exclusion may not apply to you. Some states do not allow limitations on how long an implied warranty lasts, so the above limitation may not apply to you. This warranty gives you specific legal rights, and you may also have other rights which may vary from state / province to state / province. This warranty is completely transferable to any and all future owners of this product, provided no alterations have been made to the product.

HOW TO SUBMIT YOUR REGISTRATION:

Step 1

Fill out this information for your own records.

Date of Purchase

Product & Model

Dealer Name

Serial No.

Step 2

Go online to teeter.com to register your warranty.

If you are unable to go online, you can request a warranty card to be mailed to you by calling Customer Service at 800-847-0143.

Please DO NOT mail this to Teeter.



This page intentionally left blank.

TERMS & CONDITIONS OF PURCHASE

YOUR PURCHASE IMPLIES AGREEMENT TO THE FOLLOWING TERMS, which were made available to you prior to purchase via Teeter-owned web properties (including but not limited to teeter.com and forwarding URL's like tryteeter.com and tryfreestep.com) ("Sites") or by contacting Teeter Customer Service. Your purchase signifies your agreement to all terms, conditions, and notices contained or referenced herein. If you do not agree to these Terms of Use ("Terms"), you may return the product (unopened and unused), for a refund in accordance with the Teeter Return Policy within 60 days of your first order of any Teeter products. THESE TERMS CONTAIN AN ARBITRATION AGREEMENT AND CLASS ACTION WAIVER. READ THEM CAREFULLY, BECAUSE THEY AFFECT YOUR LEGAL RIGHTS.

The terms and conditions marked with a * only apply to purchases made direct from Teeter (via phone or Sites). If your purchase was made through a Teeter Authorized Dealer, the * terms and conditions are dictated by that dealer.

CONTACT INFORMATION: Teeter is authorized to use any phone number you provide to contact you for account maintenance and billing purposes.

OUR GUARANTEE*: All of our products carry a specific money-back guarantee starting from the date that the product is delivered to you. Please review the information provided with your product for specific details. For information regarding product returns, please review our Return Policy below.

Teeter also offers a 30-Day Price Match Guarantee. If at any time within 30 days of placing your order, you find the same, new-condition model advertised in print or online by a Teeter authorized dealer for a lower price, send Teeter customer service a copy of the ad (dated and published within 30 days of placing your order) and they will either adjust your future payments for the new price or refund you the difference.

SHIPPING*: Unless otherwise noted, Teeter will use commercially-practical efforts to ship products within a reasonable time after receipt of your properly completed order. Although Teeter may provide delivery or shipment timeframes or dates, you understand that those are good-faith estimates and may be subject to change. You further understand that product availability may be limited and particular products may not be available for immediate delivery, in which case the products will be delivered when available. Teeter shall not be liable for any loss, damage, cost, or expense related to any delay in shipment or delivery.

AUTOMATIC RENEWAL / AUTO-SHIP PROGRAMS*: With regards to any product made available to you on an auto-renew or monthly (or other period) subscription as sold through the Site or otherwise (including any free trial product) (the "Product"), the default term of our agreement shall be for so long as we make the Product available to you. IF YOU HAVE PROVIDED US WITH A VALID CREDIT CARD NUMBER OR AN ALTERNATE PAYMENT METHOD, YOUR SUBSCRIPTION WILL BE AUTOMATICALLY RENEWED (AND CHARGED TO THE ACCOUNT YOU HAVE PROVIDED) FOR ANOTHER TERM AT THE EXPIRATION OF YOUR CURRENT TERM, WHENEVER LOCAL REGULATIONS ALLOW, FOR A FEE NO GREATER THAN OUR THEN-CURRENT PRICE, EXCLUDING PROMOTIONAL AND DISCOUNT PRICING.

The new term will be for the same duration as the expired term unless otherwise specified at time of renewal. This renewal will be processed (and your card charged) within 30 days prior to the expiration of the term and each period thereafter. IF YOU DO NOT DESIRE TO HAVE YOUR SUBSCRIPTION AUTOMATICALLY RENEWED, YOU MUST, PRIOR TO THE EXPIRATION OF YOUR SUBSCRIPTION TERM, INFORM US OF YOUR INTENTION NOT TO RENEW YOUR SUBSCRIPTION TO THE PRODUCT BY CALLING OUR CUSTOMER SERVICE.

You must provide current, complete, and accurate information for your billing account. You are responsible for ensuring this information is correct and must promptly update all information to keep your billing account current, complete, and accurate (such as a change in billing address, credit card number, or credit card expiration date). You must promptly notify us if your credit card is canceled (for example, for loss or theft). Changes to such information can be made by contacting Customer Service.

We reserve the right to refuse or discontinue the supply of the Product to any user at any time at our sole discretion.

RETURNS*: If you wish to return your purchase, contact Teeter Customer Service and request a Return Authorization within 90 days (or within 30 days to avoid your first payment if financed), then follow the proceeding return instructions. When an item is returned, the refund and how the refund is issued may differ based on the condition of the item, the timeframe, and how the item was purchased. Teeter offers a 90-day return window (from the date item is received) to return the product for a full refund (less return shipping and interest). Returns are allowed past the return window up to 120 days after receipt for partial credit of the original purchase price (see below). The customer is responsible for the cost of shipping the product back to Teeter unless the product is defective, in which case Teeter must be given the opportunity to offer warranty service or replace the product.

If You Return:	You'll Receive:
Item(s) in original condition within the return window (90-days from receipt after delivery)	100% of the item's price [^] (less shipping & handling, financing interest paid is non-refundable)
Item(s) in original condition past the return window (91-120 days. No returns are accepted past 120 days)	80% of the item's price [^] (financing will be refunded and separately charged a restocking fee equal to 20% of the purchase price)
Items that are returned damaged, missing parts, not in the original condition, or have obvious signs of use (reasons not due to a Teeter error)	Up to 50% of the item's price (financing will be refunded and separately charged a restocking fee equal to 50% of the purchase price)

[^] Refunds are for product only and do not include any processing, interest, shipping or handling fees. Freight on refused deliveries will be deducted from the credit or charged to account number on file.

Returns must have a valid Return Merchandise Authorization (RMA) number issued by Teeter. If merchandise delivery is refused without inspection, the refund will be for the purchase price, less all shipping charges (original and return) and trial fees. The product must be returned in original condition undamaged with all parts and support materials in its original carton. Refunds are for product only and do not include any processing fees, trial fees, shipping or handling fees. Freight on refused deliveries will be deducted from the credit. All return shipping charges must be prepaid; C.O.D. deliveries are not accepted. It is recommended that you acquire shipment tracking and insurance for the entire value of your product. We do not assume responsibility for merchandise damaged or lost during transit. Refunds are issued after a product is received and inspected; processing can take up to ten (10) days. For products on a multi-payment plan, payments will continue to charge to the credit card on file until the product is received and processed at our warehouse. Refunds, including gift returns, are made in the same form as the original payment for purchase. Please allow up to eight (8) weeks for your bank or credit card company to post this refund on your statement. Merchandise returned without a valid RMA number or in violation of this policy will not qualify for a refund. Teeter will discard the product and the customer will be responsible for any remaining payment due.

All shipments leave the Teeter warehouse in good condition. Any damage, shortages, or product lost in transit should be reported to Teeter within fourteen (14) days.

PRODUCT DESCRIPTIONS AND PRICING*: For questions about Teeter products or services, or for questions about orders placed through the Sites or otherwise, please contact Teeter Customer Service at 800-847-0143 or email at info@teeter.com.

Teeter and its affiliates attempt to be as accurate as possible. However, Teeter does not warrant that product descriptions or other content is accurate, complete, reliable, current, or error-free. If a product offered by Teeter itself is not as described, your sole remedy is to return it in unused condition.

In ordering products, you agree to provide only true, accurate, current, and complete information. You hereby certify that any e-mail account you provide to Teeter is registered to you. Teeter reserves the right to bar your access to and use of the Sites or further business transactions if it has reasonable grounds to believe that you have provided untrue, inaccurate, not current, or incomplete information to Teeter. You agree that if you are ordering or purchasing products on behalf of a company, that you have sufficient authority to bind that company to the Terms. You agree that your placement of an order is sufficient to satisfy the Statute of Frauds, and no further writing is required.

All prices are quoted in U.S. dollars. Teeter may prohibit delivery to addresses outside the United States and Canada. Teeter will add shipping and handling fees and applicable sales/use tax. Products are available while supplies last. Descriptions of, or references to, products not owned by Teeter do not imply endorsement of that product, or constitute a warranty, by Teeter.

TAXES: For current sales tax collection information, go to teeter.com/support/tax-disclaimer.

DISPUTE RESOLUTION BY INDIVIDUAL BINDING ARBITRATION: You and Teeter agree that any dispute between us (including disputes against any agent, employee, subsidiary, affiliate, predecessor in interest, successor, or assign of the other) relating to the Sites; any transaction or relationship between us resulting from your use of the Sites; the purchase, order, installation, or use of Teeter products or services; or communications between us; will be resolved exclusively and finally by binding arbitration and the arbitration decision may be enforced and judgment entered thereon in any court of competent jurisdiction. You and Teeter further agree that this arbitration agreement is made pursuant to a transaction involving interstate commerce and shall be governed by the Federal Arbitration Act (“FAA”), and not by any state law concerning arbitration. You and Teeter further agree that any determination regarding the applicability, enforceability, or validity of this arbitration agreement will be made by the arbitrator, not by any court. **BY AGREEING TO THIS ARBITRATION AGREEMENT, YOU ARE GIVING UP YOUR RIGHT TO GO TO COURT, INCLUDING YOUR RIGHT TO A JURY TRIAL.** In arbitration, a dispute is resolved by a neutral arbitrator or panel of arbitrators, rather than by a judge or jury. Arbitration is more informal; however, an arbitrator can award the same relief that a court can award. The arbitration will be administered by the American Arbitration Association (“AAA”), and conducted under AAA’s Commercial Arbitration Rules and the Supplementary Procedures for Consumer Related Disputes (collectively, the “AAA Rules”) then in effect at the time of the dispute. You may obtain copies of the AAA Rules and forms and instructions for initiating arbitration by visiting the AAA website at www.adr.org, or by calling AAA at 800-788-7879. If you initiate arbitration, Teeter will promptly reimburse you for any standard filing fee which may have been required under AAA’s Procedures once you have notified Teeter in writing and provided a copy of the arbitration proceedings. However, if Teeter is the prevailing party in the arbitration, applicable law may allow the arbitrator to award attorneys’ fees and costs to Teeter. If for any reason the AAA is unavailable, the parties shall mutually select another arbitration forum. There shall be no right or authority for any claim to be arbitrated on a class action basis or in a purported representative capacity. No claim submitted to arbitration is heard by a jury or may be brought as a private attorney general. You do not have the right to act as a class representative or participate as a member of a class of claimants with respect to any claim submitted to arbitration. The arbitrator may not consolidate more than one person’s claims against Teeter and may not preside over any kind of representative or class proceeding against Teeter. You acknowledge that this class action waiver is material and essential to the arbitration of any disputes between the parties and is nonseverable from the agreement to arbitrate claims. If any portion of this class action waiver is limited, voided, or cannot be enforced, then the parties’ agreement to arbitrate shall be null and void. **YOU UNDERSTAND THAT BY AGREEING TO THIS CLASS ACTION WAIVER, YOU MAY ONLY BRING CLAIMS AGAINST US IN AN INDIVIDUAL CAPACITY AND NOT AS A PLAINTIFF OR CLASS MEMBER IN ANY PURPORTED CLASS ACTION OR REPRESENTATIVE PROCEEDING. IF YOU DO NOT AGREE TO THIS ARBITRATION AGREEMENT AND CLASS ACTION WAIVER, YOU MUST TELL US IN WRITING, NOT USE THE SITES OR TEETER PRODUCTS, AND RETURN THE PRODUCT (UNOPENED AND UNUSED) FOR A REFUND IN ACCORDANCE WITH THE TEETER RETURN POLICY WITHIN 30 DAYS OF YOUR FIRST ORDER OF ANY TEETER PRODUCTS.**

INDEMNIFICATION: NOT ALL HEALTH AND FITNESS PROGRAMS/PRODUCTS ARE SUITABLE FOR EVERYONE AND THIS OR ANY PRODUCT MAY RESULT IN INJURY. CONSULT YOUR DOCTOR BEFORE UTILIZING THIS OR ANY HEALTH OR FITNESS-RELATED PROGRAM/PRODUCT.

To reduce the risk of injury, read and understand the User Guide and/or all accompanying product support before use. If you experience pain or discomfort during use, stop immediately and consult your doctor.

You hereby fully release and agree to indemnify and hold harmless Teeter, its parents, subsidiaries, affiliates, successors, assigns, and their respective officers, directors, members, shareholders, employees, agents, and suppliers from any claim, action, demand, loss, or damages (including attorneys’ fees) arising out of or relating to your use of the Sites, the products, exercises, instructions, or advice on the Sites, or your violation of these Terms or the rights of any third party in connection with the foregoing.

Although Teeter strives to prevent the introduction of viruses and other malware to this Site, Teeter does not warrant, guarantee, or make any representation that the Sites are free of destructive materials. Further, Teeter does not warrant or guarantee that access to this site will be uninterrupted, timely, secure, or error-free, or that defects, if any, will be corrected.

DISCLAIMER OF WARRANTY AND LIMITATION OF LIABILITY FOR USE OF WEBSITE, IF APPLICABLE: The information, products and services on the Teeter Sites are provided on an “AS IS,” and “AS AVAILABLE” basis. Teeter does not warrant the information or services provided herein or your use of the Sites generally, either expressly or impliedly, for any particular purpose and expressly disclaims any implied warranties, including but not limited to, warranties of title, non-infringement, merchantability or fitness for a particular purpose. Teeter will not be responsible for any loss or damage that could result from interception by third parties of any information or services made available to you via the Sites. Although the information provided to you on the Sites is obtained or compiled from sources we believe to be reliable, Teeter cannot and does not guarantee the accuracy, validity, timeliness or completeness of any information or data made available to you for any particular purpose. Neither Teeter nor any of its parents, subsidiaries, affiliates, successors, assigns, and their respective officers, directors, members, shareholders, employees, agents, suppliers, nor any third party vendor, will be liable or have any responsibility of any kind for any loss or damage that you incur in the event of any failure or interruption of the Sites, or resulting from the act or omission of any other party involved in making the Sites, the data contained herein or the products or services offered on the Sites available to you, or from any other cause relating to your access to, inability to access, or use of the Sites or these materials, whether or not the circumstances giving rise to such cause may have been within the control of Teeter or of any vendor providing software or services. In no event will Teeter or any such parties be liable to you, whether in contract or tort, for any direct, special, indirect, punitive, consequential or incidental damages, attorney fees, or any other damages of any kind even if Teeter or any other such party has been advised of the possibility thereof. This limitation on liability includes, but is not limited to, the transmission of any viruses which may infect a user’s equipment, failure of mechanical or electronic equipment or communication lines, telephone or other interconnect problems (e.g., you cannot access your internet service provider), unauthorized access, theft, operator errors, strikes or other labor problems or any force majeure. Teeter cannot and does not guarantee continuous, uninterrupted or secure access to the Web site.

COPYRIGHT: All content included on Teeter Sites, product, and product support, including design, product descriptions, and multimedia content, is the property of Teeter or its content suppliers and protected by United States and international copyright laws.

TRADEMARKS: Teeter, Teeter Move, FitSpine, FitForm, Power 10, DEX, Flex Technology, EZ-Up, ProFlex, “Feel Better, Move Better, Live Better”, “Better Back, Better Body” and other Teeter trademarks and service marks referenced on Sites or in commerce are registered by Teeter. The names of other companies and marks used on third-party products or services mentioned herein may be registered trademarks and service marks or trademarks and service marks of their respective companies and/or owners.

You are prohibited from using our trademarks (and any third-party trademarks) for any purpose including, but not limited to use as meta tags on other pages or sites on the World Wide Web without the written permission of Teeter or such third party, which may own the marks.

PRIVACY POLICY*: Users of Teeter Sites should refer to the Teeter online Privacy Policy for information about how Teeter uses and collects information. You agree that Teeter may disclose your personal information to a third party if Teeter believes in good faith that the law or legal process requires it, to protect the rights or property of Teeter or others, or as otherwise described in the Teeter Privacy Policy at teeter.com.

JURISDICTION: These Terms, as well as the Privacy Policy for the Sites, and any dispute that may arise between you and Teeter, shall be governed by and construed in accordance with the laws of the State of Washington, U.S.A., without regard to conflict of laws principles.

Unless otherwise specified herein, these Terms and the Site’s Privacy Policy constitute written agreements between you and Teeter and supersedes all prior or contemporaneous communications and proposals (whether oral, written, or electronic) between you and Teeter. A printed version, and of any electronic notices pertaining to the same, shall be admissible in a judicial or administrative proceeding to the same extent, and subject to the same restrictions, as any other contract, document or record originally in printed form.

If any provision of these Terms shall be deemed unlawful, void, or for any reason unenforceable, then that provision shall be deemed severable from these Terms and shall not affect the validity and enforceability of any remaining provisions.

The terms of this section survive any termination of the Terms.

This page intentionally left blank.

This page intentionally left blank.

FIND MORE AT TEETER.COM

Better Back™ Foam Rollers

Prepare the body for movement, accelerate recovery, minimize muscular imbalances, and improve overall flexibility with the Teeter collection of textured Foam Rollers.

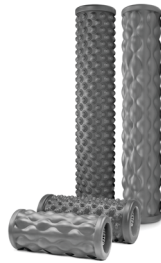

FitForm™ Cable Trainer

Work your arms, legs and core with micro-adjusting resistance up to 65 lb. It's total body strengthening in one small package!



Power10™ Elliptical Rower

Torch more calories and enhance muscle definition with 2-way resistance. The patented elliptical path delivers low-impact cardio while you engage more muscles with every workout.



FreeStep® Recumbent Cross Trainer

Experience feel-good exercise with zero-impact cardio and strength! The ONLY home-use machine with patented smooth-stride technology found in high-end seated physiotherapy steppers.



LX9™ Inversion Table

Get your happy back with the premier Teeter Inversion Table featuring the FlexTech™ 8-Pt Floating Suspension Bed that flexes as you move, Deluxe EZ-Reach™ Handle, and so much more!



Heavy-Duty Equipment Mat

Protect your floors from wear and tear, and extend the life of your equipment by preventing floor dust and debris from getting into moving parts.

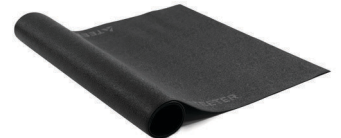

Coaching Every Step of the Way



TEETER MOVE[®]

Access workouts and instructions anytime, anywhere. Our guided personal training is available to you with the free Teeter Move app.

Designed to help you stay motivated and moving forward in your strength, endurance, and mobility training.



On-Demand Support

Access our online support portal for live chat, video tutorials, virtual troubleshooting, warranty part requests, and more.

800-847-0143

support@teeter.com

teeter.com/support



U.S. and Foreign Patents Apply. Teeter and Teeter logo are registered trademarks of Teeter. Specifications subject to change without notice.
© COPYRIGHT 2023 Teeter. International Law Prohibits Any Copying. PF1040 1023-0