



NEW!
Follow along with
your smartphone
to make assembly
even easier!

EZ-Up™ Chin-Up & Inversion Rack and System

Assembly Instructions



* Specifications may vary from this image and are subject to change without notice.



To download and print Teeter's EZ-Up™ Chin-Up & Inversion Rack Instructions, visit the product support page at teeter.com.



Congratulations on your purchase of the Teeter EZ-Up™ Chin-Up Inversion Rack! This product has been designed as a multi-functional fitness tool, to be ideally paired with Teeter EZ-Up™ Gravity Boots to ensure the most comfortable and effective inversion experience.

In order to utilize this product to its fullest extent, it is critical that you follow the assembly instructions, read and fully understand the Assembly and User Instructions, and review the Getting Started DVD prior to using your new Teeter EZ-Up Chin-Up Inversion Rack.



For step-by-step, 3D interactive instructions, download BILT (a FREE mobile app) to your smartphone to follow along. See Page 5 for instructions on how to download BILT.



To register your product warranty, go to **teeter.com/Support/Warranty-Registration**



If you have any questions concerning assembly or if any parts are missing, **DO NOT RETURN THE ITEM TO THE STORE OR CONTACT THE RETAILER.** Our dedicated customer service experts can help! Contact Teeter Customer Service at **800.847.0143**, or via online forms or Live Chat at **teeter.com**.

Assembly Instructions

Important Safety Instructions	1
Items for Assembly	2
Understanding Your Inversion Rack.....	3
Safety Warning Labels & Product Specifications.....	4
Before Beginning Assembly.....	5
Assembly Steps.....	6 – 12
Warranty Terms & Registration.....	13

BEFORE YOU BEGIN: Review all steps before beginning assembly and read all precautions before use. Carefully adhere to the Instructions to help ensure safety and product integrity. The below warnings and subsequent instructions assume use of the Inversion Rack with Teeter's EZ-Up Gravity Boots. Be sure to also review the materials that accompany the Gravity Boots.

IMPORTANT SAFETY INSTRUCTIONS READ ALL INSTRUCTIONS BEFORE USING THE EZ-UP CHIN UP & INVERSION RACK

WARNING

FAILURE TO FOLLOW INSTRUCTIONS AND WARNINGS COULD RESULT IN SERIOUS INJURY OR DEATH.

To reduce the risk of injury:

- Read and understand all the instructions, review all other accompanying documents, and inspect the equipment before using the Inversion Rack. It is your responsibility to familiarize yourself with the proper use of this equipment and the inherent risks of inversion if these instructions are not followed, such as falling on your head or neck, pinching, entrapment, equipment failure or aggravating a pre-existing medical condition. It is the responsibility of the owner to ensure that all users of the product are fully informed about the proper use of the equipment and all safety precautions.
- **ALWAYS** read and understand the instructions and warnings associated with and accompanying any supplementary equipment, such as Teeter EZ-Up Gravity Boots.
 - **DO NOT** use until approved by a licensed physician. Inversion is contraindicated in any medical or health condition that may be made more severe by an elevation of blood pressure, intracranial pressure or mechanical stress of the inverted position, or that may impact your ability to operate the equipment. This may include injury or illness, but also the side effects of any drug or supplement (prescribed or over-the-counter). Specific conditions may include, but not be limited to:
 - Any condition, neurological or otherwise, which results in unexplained tingling, weakness or neuropathy, seizure, sleep disorder, lightheadedness, dizziness, disorientation, or fatigue, or impacts strength, mobility, alertness, or cognitive ability;
 - Any brain condition, such as trauma, history of intracranial bleed, history or risk of TIA or stroke, or severe headaches;
 - Any condition of the heart or circulatory system, such as high blood pressure, hypertension, increased risk of stroke, or use of anticoagulants (including high doses of aspirin);
 - Any bone, skeletal or spinal cord condition or injury, such as significant spinal curvature, acutely swollen joints, osteoporosis, fractures, dislocations, medullary pins or surgically implanted orthopedic supports;
 - Any eye, ear, nasal or balance condition, such as trauma, history of retinal detachment, glaucoma, optic hypertension, chronic sinusitis, middle or inner ear disease, motion sickness, or vertigo;
 - Any digestive or internal condition, such as severe acid reflux, hiatal or other hernia, gallbladder or kidney disease;
 - Any condition for which exercise is specifically directed, limited or prohibited by a physician, such as pregnancy, obesity, or recent surgery.
- **ALWAYS** install Locking Brackets in a SOLID WOOD doorway built according to U.S. national building codes, which measures between 28-36 in (71.1-91.4 cm) wide and has been built according to U.S. national building codes. **DO NOT** use in faux or metal doorways.
- When using with Gravity Boots, **ALWAYS** be certain the Gravity Boots are properly adjusted and that your ankles are secure before using the equipment. Ensure that the Gravity Boots are snug, close fitting and secure EVERY TIME you use the equipment.
- When using the Gravity Boots, **ALWAYS** wear securely tied lace-up shoes, such as normal style tennis shoes. **DO NOT** wear clothing or footwear that can interfere with securing the Gravity Boots, such as high-tops or any shoes that extend above the ankle bones.
- When using the Gravity Boots with EZ-Up Rack or Bar, **ALWAYS** install the EZ-UP Strap to provide assistance with dismount.
- When using the Gravity Boots, **ALWAYS** ensure that the Boots are put on the correct leg so that the buckle levers are on the outside of the leg, versus on the inside where they can rub against each other and unlatch or sustain potential damage.
- When using non-Teeter brand inversion boots, ensure boot hook is compatible with 1.25 in (3.2 cm) diameter bar.
- New users will require the assistance of a spotter possessing the physical strength to lift and return the user to the upright position.
- **DO NOT** continue using the equipment if you feel pain or become light-headed or dizzy. If this occurs while inverting, immediately return to the upright position for recovery and eventual dismount by following the dismounting instructions.
- **DO NOT** use if you are over 250 lbs (113.4 kg) or use by more than one person at a time, otherwise structural failure could occur. **DO NOT** use until the Inversion Rack is tested to exceed your body weight by following the weight test instructions. If the doorframe cracks or any structural failure or weakened condition is observed, **DO NOT** continue use of the Inversion Rack in that doorframe.
- **DO NOT** invert on the Inversion Rack if your height exceeds the distance between the upper bar of the installed Inversion Rack and the floor. **DO NOT** invert from the lower bar. Maximum height allowance depends on the height of the doorway and placement of the locking brackets. In a standard 6'8" (203.2 cm), maximum user height is 7'3" (221 cm).
- **DO NOT** allow children to use the equipment. Keep children, bystanders, and pets away from the equipment while in use. The Inversion Rack is not intended for use by persons with reduced physical, sensory or mental capabilities.
- **DO NOT** store outdoors.
- **DO NOT** use aggressive movements, bounce or swing excessively. While inverted, **DO NOT** use weights, elastic bands, any other exercise or stretching device or non-Teeter attachments. Use the Inversion Rack only for its intended use as described in these instructions.
- **DO NOT** exercise to the point of fatigue while inverted, otherwise returning upright or dismounting may be difficult.
- **DO NOT** use in any commercial, rental or institutional setting. This product is intended for indoor, home-use only.
- **DO NOT** operate equipment while under the influence of drugs, alcohol, or medication that may cause drowsiness or disorientation.
- **ALWAYS** inspect the equipment and the doorframe prior to use. Make sure all fasteners and Locking Brackets are secure.
- **ALWAYS** replace defective components immediately and/or keep the equipment out of use until repair.
- Refer to additional warning notices posted on the equipment. If a product label should become lost, damaged or illegible, contact Customer Service for a replacement.

SAVE THESE INSTRUCTIONS

Items for Assembly Instructions

Items not shown to scale. Hardware drawings located on the insert inside each Hardware Kit.

Carefully remove the individual parts from the carton. You should have all of the items listed below. If any items are missing or damaged, contact your retailer or Teeter Customer Service directly.

ITEM NO.	ITEM NAME
Large Bar Assembly	
E11040	Large Diameter "L" Bar
E11043	Large Straight Bar w/ Foam Grips
E11052	Large Diameter "Elbow" Bar
E11060	Large Assembly Hardware Kit
Small Bar Assembly	
E11047	Small Diameter "L" Bar
E11050	Small Straight Bar w/ Warning Label
E11054	Small Diameter "Elbow" Bar
E11061	Small Assembly Hardware Kit

ITEM NO.	ITEM NAME
Mounting Assembly	
E11038	Large Locking Bracket (1)
E11005	Small Locking Bracket (1)
E11059	Mounting Assembly Hardware Kit
Attachments	
E11015	EZ-Up Strap
Product Support	
LD1005	Getting Started DVD
LE1019	Owner's Manual
Not Included	
Medium Philips Head Screwdriver, Adjustable Wrench, Drill Motor w/ 5/32" Drill Bit	

Large Bar Assembly

Use with Large Assembly Hardware Kit (E11060)

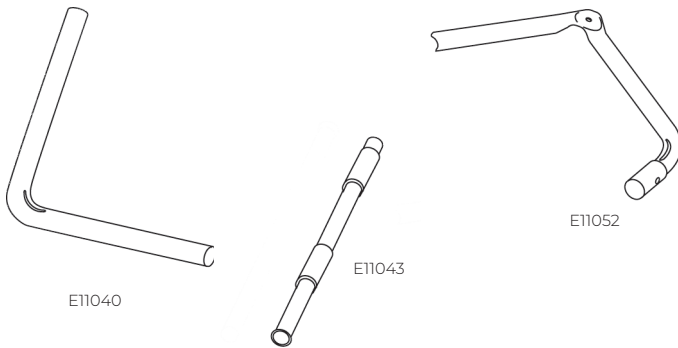

Small Bar Assembly

Use with Small Assembly Hardware Kit (E11061)

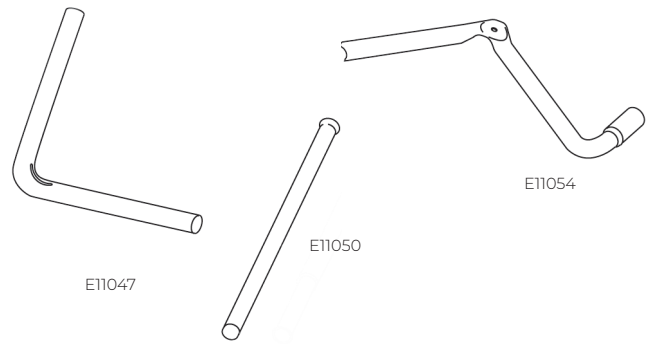

Mounting Assembly

Use with Mounting Assembly Hardware Kit (E11059)



Large Locking Bracket

Small Locking Bracket

E11038

E11005

Attachments

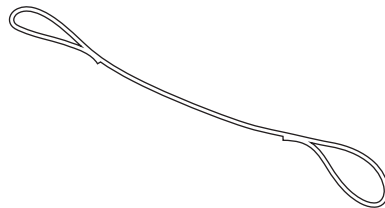

EZ-Up Strap

E11015

Product Support

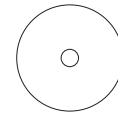

Getting Started DVD

LD1005

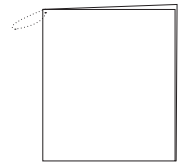

Owner's Manual

LE1019

Understanding Your EZ-Up Rack

Before reading further, study the drawing below to familiarize yourself with the important assembled components of your EZ-Up Rack.



Identifying Assembled Parts and Components

1	Upper Bar	4	Door Savers
2	Lower Bar with Grips	5	Locking Brackets
3	EZ-Up Handles	6	EZ-Up Strap

Safety Warning Labels & Product Specifications

Important: Please review all labels and supporting materials before using your EZ-Up Rack.

This drawing indicates the locations of the warning labels found on your product. If a label is missing, illegible or removed, contact Teeter Customer Service to request a complimentary replacement label.

Note: Image and labels below not shown at actual size.

⚠ WARNING

SERIOUS INJURY OR DEATH MAY OCCUR IF PRECAUTION IS NOT TAKEN DURING USE OR IF THE PRODUCT IS IMPROPERLY ASSEMBLED AND INSTALLED. To reduce this risk:

- **READ and understand all** warnings and instructions in the Assembly Instructions and Owner's Manual before assembling or attempting to use.
- **ONLY** install Locking Brackets in a **SOLID WOOD** doorway built according to national building codes. Maximum door width 36 in (91.4cm). Use only the hardware provided. **DO NOT** use in faux or metal doorways.
- **DO NOT** invert until properly weight / height tested as defined in Assembly Instructions. Use a spotter until comfortable.
- **DO NOT** overexert yourself while inverted, otherwise returning upright may be difficult.
- **DO NOT** allow children on this product. **Keep children, bystanders and pets away** when in use.
- **Weight Capacity: 250 lb (113.6 kg). For consumer, indoor Home-Use Only.**

Replace label if damaged, illegible or removed.



⚠ WARNING

SERIOUS INJURY OR DEATH MAY OCCUR. To reduce this risk:

- **ALWAYS** attach EZ-Up Strap to the inversion bar as shown in the Owner's Manual. **DO NOT** use this strap with inversion tables.
- **ALWAYS** store EZ-Up Strap after use according to directions in the Owner's Manual

Replace label if damaged, illegible or removed.

Assembled DIMS: 39 in x 23 in x 9 in (99 cm x 58 cm x 22.9 cm)
Weight: 24 lbs.

Before Beginning Assembly

Unpack and Prepare Your Workspace

- Unpack all parts and support materials. Set aside packing materials and clear your work area.
- Locate the Hardware Kits, packaged with the manuals. They are labeled to correspond with the assembly process.
- The Getting Started DVD provides step-by-step instruction on how to assemble and use your product. You may find it helpful to follow along with the DVD by watching it on either your TV or computer. The DVD is divided into the following sections:
 - **Assembly Instructions:** Follow step-by-step instructions on how to assemble your EZ-Up Rack.
 - **User Instructions:** Learn how to mount and dismount the EZ-Up Rack with EZ-Up Gravity Boots, as well as perform inverted and non-inverted exercises.

Making Assembly Even Easier with **BILT**.



For step-by-step, 3D interactive instructions, download BILT (a FREE mobile app) to your smartphone to follow along. Simply download the BILT app by scanning the QR code below and then search for **Teeter EZ-Up Inversion & Chin-Up Rack** within the BILT app to get started!



STEP ①

Assemble Large Diameter Bars

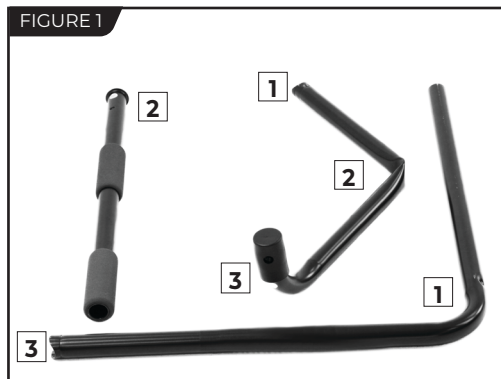

- Locate the three (3) bars for the Large Bar Assembly, marked with Joint numbers 1, 2, and 3 (Figure 1). Locate the Large Assembly Hardware Kit (E11060).
- Position the Large Diameter “L” Bar and Large Diameter “Elbow” Bar together, aligning joints marked as 1 and joints marked as 3 (Figure 2).

· Assemble Joint 1 (Figure 2A):

- » Seat the curved flange at the end of the “Elbow” Bar over the hole on the “L” Bar.
- » Insert and loosely hand-tighten a 2 inch (5 cm) bolt through the “L” Bar into the flange in the “Elbow” Bar. Do not fully tighten yet.



· Assemble Joint 3 (Figure 2B):

- » Seat the end of the “L” Bar inside the large opening in the Door Saver on the “Elbow” Bar.
- » Insert and loosely hand-tighten a 2 inch (5 cm) bolt through the outside of the Door Saver into the end of the “L” Bar. Do not fully tighten yet.

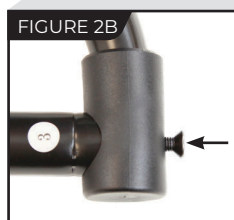
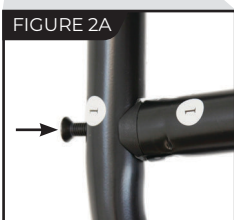

· Assemble Joint 2 (Figure 3A):

- » With the countersink pointing down, align the hole in the Straight Bar underneath the “Elbow” Bar,
- » Insert the 1 ¾ inch (4.4 cm) bolt under the Straight Bar into the countersink and through the “Elbow” Bar. Hand tighten with the nut. Do not fully tighten yet.

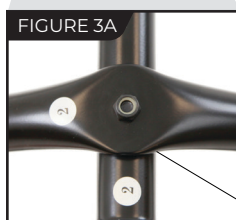
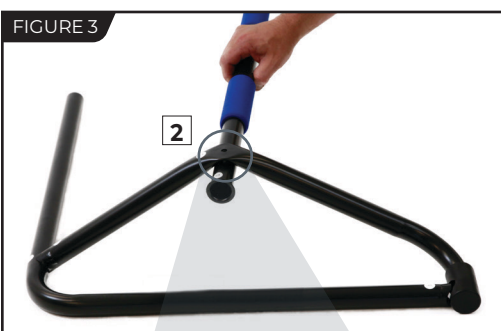

Countersink

STEP ②

Assemble Small Diameter Bars

- Locate the three (3) bars for the Small Bar Assembly, marked with Joint numbers 4, 5, and 6 (Figure 4). Locate the Small Assembly Hardware Kit (E11061).

- Position the Small Diameter “L” Bar and Small Diameter “Elbow” Bar together, aligning joints marked as 5 and joints marked as 6 (Figure 5).

- **Assemble Joint 5** (Figure 5A):

- » Seat the curved flange at the end of the “Elbow” Bar over the hole on the “L” Bar.
- » Insert and loosely hand-tighten a 2 inch (5 cm) bolt through the “L” Bar into the flange in the “Elbow” Bar. Do not fully tighten yet.

- **Assemble Joint 6** (Figure 5B):

- » Seat the end of the “L” Bar inside the large opening in the Door Saver on the “Elbow” Bar.
- » Insert and loosely hand-tighten a 2 inch (5 cm) bolt through the outside of the Door Saver into the end of the “L” Bar. Do not fully tighten yet.

- Position the Straight Bar and Large Diameter “Elbow” Bar together, aligning the joint marked as 4 (Figure 6).

- **Assemble Joint 4** (Figure 6A):

- » With the countersink pointing down, align the hole in the Straight Bar underneath the “Elbow” Bar,
- » Insert the 1 ½ inch (3.8 cm) bolt under the Straight Bar into the countersink and through the “Elbow” Bar. Hand tighten with the nut. Do not fully tighten yet.

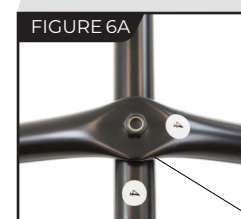
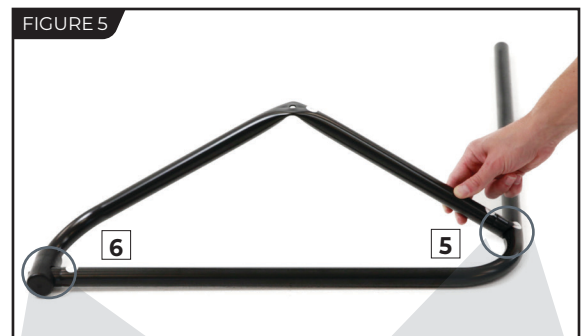
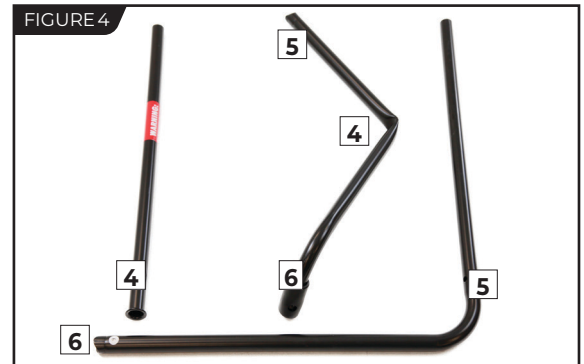

Countersink

STEP ③

Attach Large & Small Assemblies

FIGURE 7



· Align and slide the Small Bar Assembly (labeled 4, 5, 6) into the Large Bar Assembly (labeled 1, 2, 3) (Figures 7 & 8).

· The width of the EZ-Up Rack may be adjusted by sliding the Small and Large Assemblies in or out (Figure 9), to fit doorways between 28 in - 36 in (71 - 91.4 cm) wide. For purpose of assembly, slide to the narrowest width.

FIGURE 8

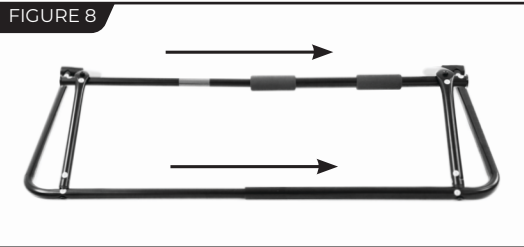

· **SECURELY TIGHTEN ALL BOLTS and NUTS** (3 on each side) using a screwdriver and wrench.

FIGURE 9

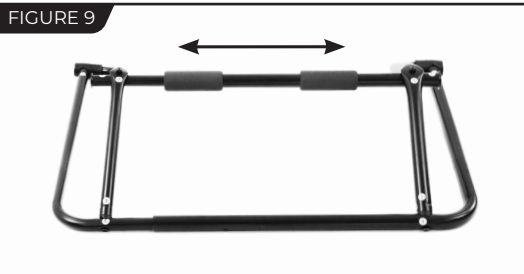

STEP 4

Install Locking Brackets

⚠ WARNING

Serious injury or death may occur if the Inversion Rack is not installed in the doorframe properly: **ALWAYS** securely install the Locking Brackets in **SOLID WOOD** doorways built according to U.S. national building codes (maximum width of 36 in/91.4 cm). Maximum height allowance depends on the height of the doorway and placement of the locking brackets. In a standard 6'8" (203.2 cm), maximum user height is 7'3" (221 cm).

- Locate the Mounting Hardware Kit (E11059).
 - To allow installation of the equipment without interfering with the operation of the door, mount the Locking Brackets on the side of the doorframe opposite from the hinged door (Figure 10). With a pencil, mark 2 in (5 cm) down from the top of the doorframe.
 - There are two sizes of Locking Brackets, one to fit the Large Straight Bar with Grips and one to fit the Small Straight Bar. Facing the door, mount the Large Locking Bracket (A) on your **RIGHT** and the Small Locking Bracket (B) on your **LEFT** (Figure 10).
 - On the **RIGHT** side of the doorframe, place the Large Locking Bracket with the plastic rotating lock open and on top against the doorstop edge. Align the top of the Locking Bracket with the pencil mark so there is a 2 in (5 cm) clearance between the Locking Bracket and top of the doorframe (Figure 11).
- NOTE:** If you find use of the Inversion Rack difficult at this height, you may lower the Rack as long as the top bar height exceeds the height of the tallest user in the household.
- With a pencil, mark the doorframe through the three (3) screw holes in the bracket. Set the bracket aside and pre-drill 5/32 inch (3.9 mm) diameter holes where you marked the doorframe, at least 2 inches (5 cm) deep (Figure 11).
 - Mount the bracket using three (3) wood screws provided, ensuring that the screws fully engage in the doorframe. Screws must be tight and flush with the bracket. Use **ONLY** the screws provided - **DO NOT** substitute with any other screws.
 - Following the same procedure as above, install the Small Locking Bracket on the **LEFT** side, with the same distance from the top of the doorframe as the Large Locking Bracket.

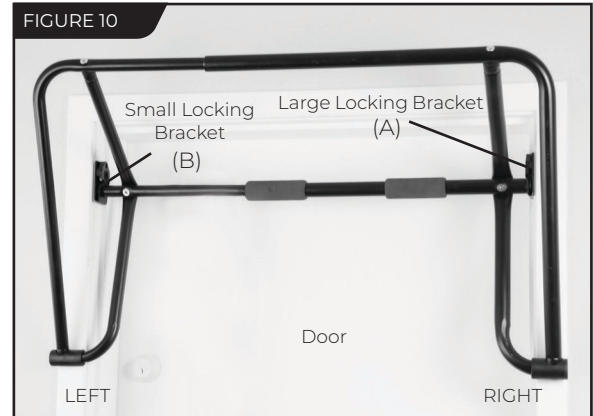

STEP 5

Install the EZ-Up Rack into Doorframe

FIGURE 12



- With the Upper Bar facing you, hold the EZ-Up Rack near the ends of the Lower Bar. Slide the flared end of the Large Straight Bar into the U-Shaped Rest in the RIGHT locking bracket (Figure 12).

- Extend the length of the EZ-Up Rack until the flared end of the Small Straight Bar can slide into the U-Shaped Rest in the LEFT locking bracket, NOT to exceed 36 in (91.4 cm) wide.

- Lock the EZ-Up Rack into the Locking Brackets by snapping the plastic, rotating locks over the top of the Lower Bar (Figure 13).

⚠ WARNING

Failure of the rotating lock to snap over the Lower Bar is indication of improper assembly and if not corrected, could result in serious injury or death! Always ensure the Locking Brackets are locked securely over the Lower Bar before use.

FIGURE 13

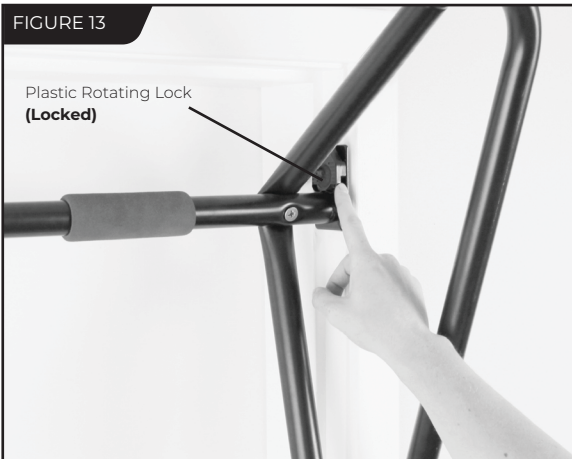

- If the EZ-Up Rack interferes with normal passage through the doorway, remove the EZ-Up Rack from the doorframe after each use by rotating the plastic, rotating locks off the Lower Bar and lifting the EZ-Up Rack out of the U-Shaped Rest.

STEP 6

Attaching & Storing the EZ-Up Strap

- Once the Rack is fully assembled and mounted to the doorframe, loop the EZ-Up Strap over the Lower Bar (Figure 14A).
- Feed the large-looped end of the strap through the small-looped end and pull until the fit is snug around the lower bar (Figure 14B).
- To store the EZ-Up Strap when not in use, loop the entire length of the strap around the Small Diameter bars and secure the end loop by tucking it behind the fully looped Strap to ensure that the Strap does not unravel (Figure 15).

⚠ WARNING

To prevent entanglement, always ensure the EZ-Up Strap is properly stored while not in use.



STEP 7

Test Weight and Height

⚠ WARNING

FAILURE to test and inspect the equipment prior to first use could result in serious injury or death!

FIGURE 16A

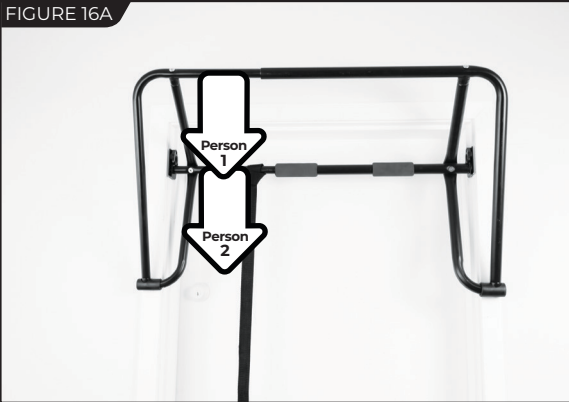

Weight Test

- After installing the Locking Brackets and securing the EZ-Up Rack in place, the user and another adult person with a combined weight equal to or greater than 1.5 times the user's weight should hang by their hands from one side (one person on the Upper Bar and one on the Lower Bar) and bounce several times applying their full weight (Figure 16A).
- Repeat the test on the other side (Figure 16B).
- If the doorframe shows cracks or any signs of instability or weakness, **DO NOT** continue use of the EZ-Up Rack in that doorframe.

FIGURE 16B

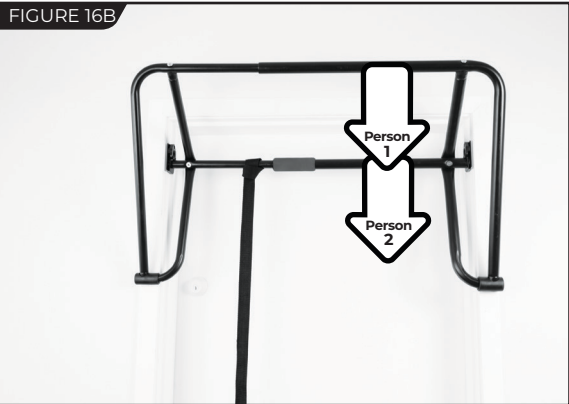

Height Test

- Measure between the Upper Bar and floor to ensure the distance is greater than the head height of the tallest user in the household (Figure 17).

FIGURE 17



The Teeter warranty set forth below and on Teeter's website applies to US and Canadian customers only. For international customers, please consult your local distributor for warranty information which will vary depending on country.



During the period starting with the day of retail purchase and continuing for five (5) years, Teeter extends to the owner a repair and replacement warranty against manufacturing defects in materials, workmanship, fabrics and padding. Teeter will repair or replace any such defect and will pay the costs of all parts, labor and transportation. If a repair or replacement is not commercially practical or cannot timely be made, then Teeter will, at the original Purchaser's option, replace with a comparable product or refund the purchase price.

Handling and transportation costs related to product warranty service only are covered by this warranty. This warranty does not cover damage resulting from improper handling, assembly, or installation, repairs made by others, accident, misuse, or abuse. Under no circumstances shall Teeter, or any other party involved in the sale of this product, have any liability for incidental or consequential damage arising from breach of an express or implied warranty on any Teeter product.

EXCEPT AS SET FORTH ABOVE, NO WARRANTY IS GIVEN WITH RESPECT TO ANY TEETER PRODUCT, AND ALL EXPRESS WARRANTIES ARE DISCLAIMED. This warranty shall be governed by the laws of the State of Washington, USA. To the extent this warranty is found not to be enforceable, it shall be deemed revised to the extent necessary to make it enforceable. This warranty and any controversy or claim arising out of this warranty or its interpretation shall be governed by the laws of the State of Washington, USA. Any controversy or claim arising out of or relating to this warranty, its interpretation, or any alleged breach thereof, which cannot be amicably settled between Teeter and the owner within sixty (60) days of written notice by the aggrieved party to the other, shall be finally settled by arbitration submitted to three (3) arbitrators selected from the panels of the arbitrators of the American Arbitration Association located closest to Teeter's principal place of business.

Some states do not allow the exclusion of incidental or consequential damage from a warranty, so the above limitation or exclusion may not apply to you. Some states do not allow limitations on how long an implied warranty lasts, so the above limitation may not apply to you. This warranty gives you specific legal rights, and you may also have other rights which may vary from state to state.

HOW TO SUBMIT YOUR REGISTRATION:

Step 1

Fill out this information for your own records.

 Date of Purchase

 Product & Model

Step 2

Go online to teeter.com to register your warranty.

 Dealer Name

If you are unable to go online, you can request a warranty card to be mailed to you by calling Customer Service at 800-847-0143. Please DO NOT mail this to Teeter.



PLEASE RETAIN THIS FOR YOUR RECORDS



Roger Teeter
Founder & Innovator



If you have any trouble assembling the equipment, or questions about its use, please contact customer service.

USA: 800-847-0143 or info@teeter.com
International: info@teeterintl.com

Check out the selection of products and accessories available at teeter.com!

USA: Teeter
9902 162nd St. Ct. E.
Puyallup, WA 98375
Toll Free: 800-847-0143
Fax: 800-847-0188
teeter.com | info@teeter.com

International: Teeter International, Ltd.
Gor-Ray House
758 Great Cambridge Rd
Enfield
Middlesex EN1 3GN
United Kingdom
teeterintl.com | info@teeterintl.com

