

# FitSpine X™ Series Inversion Tables

For gravity-assisted stretching and decompression

**FASTER, BETTER  
RESULTS WITH  
TEETER SUPPORT  
& COACHING**

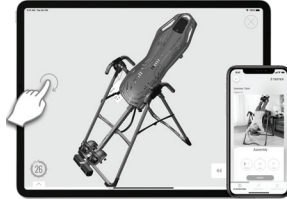

## ASSEMBLE FASTER

Free BILT® app puts easy 3-D instructions at your fingertips. Search 'Teeter' in BILT® to get started.



Scan or  
Find **BILT®** in  
your App Store

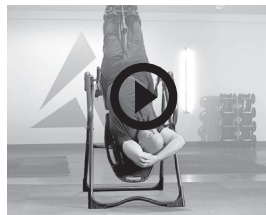

## EASY ACCESS TO VIDEO

Access videos online for easy assembly guidance, how-to's and classes.



Scan or  
Go to  
[teeter.com/videos](https://teeter.com/videos)



## FREE EXERCISE GUIDE

Register your warranty and gain access to our 30-Day Back Pain Relief Guide.



Scan or  
Go to  
[teeter.com/warranty](https://teeter.com/warranty)



## REACH YOUR GOALS

Use the free Teeter Move™ app to access guided sessions, product support, and more!



Scan or  
Find **Teeter Move™**  
in your App Store



# WELCOME TO THE TEETER FAMILY

Congratulations on your purchase of a Teeter FitSpine® Inversion Table!  
For the best experience, it is critical that you follow the assembly instructions, and read and fully understand the Owner's Manual attached to the equipment before inverting. Teeter Decompression Devices are multiple user, reusable medical devices for home use, intended to provide traction to the spine while stretching the para-spinal muscle and soft tissues. The devices provide non-powered traction and are meant for use by adults.

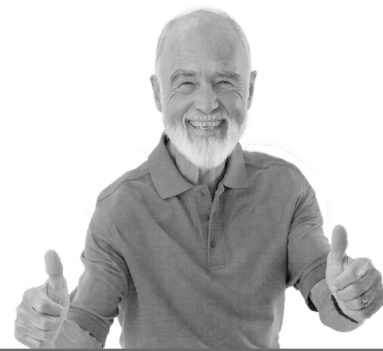

*“I created Teeter so people could live healthier and more active lives.”*

*-Roger Teeter*

Teeter inversion tables are FDA-Registered as 510(k) medical devices. Indicated for:



- Back pain
- Muscle tension
- Degenerative disc disease
- Spinal degenerative joint disease
- Spinal stenosis
- Herniated disc
- Spinal curvature due to tight muscles
- Sciatica
- Muscle spasm
- Facet syndrome

## We've Got Your Back!



If you have any questions concerning assembly or if any parts are missing, **DO NOT RETURN THE ITEM TO THE STORE OR CONTACT THE RETAILER.** Our dedicated product service experts can help! Contact Teeter Customer Service at **800-847-0143**, or via online forms or Live Chat at **teeter.com**.



Trust Teeter for unmatched quality and performance, backed by our industry-leading warranty coverage. To register your product warranty, go to **teeter.com/Support/Warranty-Registration**

## TABLE OF CONTENTS

### Assembly Instructions

Important Safety Instructions .....	1
Items for Assembly .....	2
Understanding Your Inversion Table .....	3
Safety Warning Labels & Product Specifications.....	4
Assembly Steps.....	5-14
Before Inverting .....	15
Warranty Terms & Registration.....	16

### Owner's Manual (attached to the equipment)

Important Safety Instructions .....	1
User Settings .....	2
Prepare to Invert.....	3-4
Inverting .....	4-5
Storage & Maintenance.....	5
Get the Most Out of Your Teeter.....	6

**BEFORE YOU BEGIN:** Review all steps before beginning assembly and read all precautions before using the inversion table. Carefully adhere to the Assembly Instructions and Owner's Manual to help ensure safety and product integrity.

## **IMPORTANT SAFETY INSTRUCTIONS**

### **READ ALL INSTRUCTIONS BEFORE USING THE INVERSION TABLE**

# **⚠ WARNING**

#### **FAILURE TO FOLLOW INSTRUCTIONS AND WARNINGS COULD RESULT IN SERIOUS INJURY OR DEATH.**

To reduce the risk of injury:

- Read and understand all the instructions, review all other accompanying documents, and inspect the equipment before using the inversion table. It is your responsibility to familiarize yourself with the proper use of this equipment and the inherent risks of inversion if these instructions are not followed, such as falling on your head or neck, pinching, entrapment, equipment failure, or aggravating a pre-existing medical condition. It is the responsibility of the owner to ensure that all users of the product are fully informed about the proper use of the equipment and all safety precautions.
- **DO NOT** use until approved by a licensed physician. Inversion is contraindicated in any medical or health condition that may be made more severe by an elevation of blood pressure, intracranial pressure or mechanical stress of the inverted position, or that may impact your ability to operate the equipment. This may include injury or illness, but also the side effects of any drug or supplement (prescribed or over-the-counter). Specific conditions may include, but not be limited to:
  - Any condition, neurological or otherwise, which results in unexplained tingling, weakness or neuropathy, seizure, sleep disorder, lightheadedness, dizziness, disorientation, or fatigue, or impacts strength, mobility, alertness, or cognitive ability;
  - Any brain condition, such as trauma, history of intracranial bleed, history or risk of TIA or stroke, or severe headaches;
  - Any condition of the heart or circulatory system, such as high blood pressure, hypertension, increased risk of stroke, or use of anticoagulants (including high doses of aspirin);
  - Any bone, skeletal or spinal cord condition or injury, such as significant spinal curvature, acutely swollen joints, osteoporosis, fractures, dislocations, medullary pins or surgically implanted orthopedic supports;
  - Any eye, ear, nasal or balance condition, such as trauma, history of retinal detachment, glaucoma, optic hypertension, chronic sinusitis, middle or inner ear disease, motion sickness, or vertigo;
  - Any digestive or internal condition, such as severe acid reflux, hiatal or other hernia, gallbladder or kidney disease;
  - Any condition for which exercise is specifically directed, limited or prohibited by a physician, such as pregnancy, obesity, or recent surgery.
- **ALWAYS** be certain the Ankle Lock System is properly adjusted and fully engaged, and that your ankles are secure before using the equipment. HEAR, FEEL, SEE and TEST that the Ankle Lock System is snug, close-fitting and secure EVERY TIME you use the equipment.
- **ALWAYS** wear securely tied lace-up shoes with a flat sole, such as a normal tennis-style shoe.
- **DO NOT** wear any footwear that could interfere with securing the Ankle Lock System, such as shoes with thick soles, boots, high-tops or any shoe that extends above the anklebone.
- **DO NOT** use the inversion table until it is adjusted properly for your height and body weight. Improper settings can cause rapid inversion or make returning upright difficult. New users, and users who are physically or mentally compromised, will require the assistance of a spotter. Make sure the equipment is set to your unique user settings prior to each use.
- **DO NOT** sit up or raise head to return upright. Instead, bend knees and slide your body to the foot-end of the inversion table to change weight distribution. If locked out in full inversion, follow the instructions for releasing from the locked position before returning upright.
- **DO NOT** continue using the equipment if you feel pain or become light-headed or dizzy while inverting. Immediately return to the upright position for recovery and eventual dismount.
- **DO NOT** use if you are over 198 cm / 6 ft 6 in or over 136 kg (300 lb). Structural failure could occur or head / neck may impact the floor during inversion.
- **DO NOT** allow children to use this machine. Keep children, bystanders, and pets away from machine while in use. The inversion table is not intended for use by persons with reduced physical, sensory or mental capabilities, unless they are given supervision and instruction concerning use of the machine by a person responsible for their safety.
- **DO NOT** store the inversion table upright if children are present. Fold and lay the table on the floor. **DO NOT** store outdoors.
- **DO NOT** use aggressive movements, or use weights, elastic bands, any other exercise or stretching device or non-Teeter® attachments while on the inversion table. Use the inversion table only for its intended use as described in this manual.
- **DO NOT** drop or insert any object into any opening. Keep body parts, hair, loose clothing and jewelry clear of all moving parts.
- **DO NOT** use in any commercial, rental or institutional setting. This product is intended for indoor, home-use only.
- **DO NOT** operate equipment while under the influence of drugs, alcohol, or medication that may cause drowsiness or disorientation.
- **ALWAYS** inspect the equipment prior to use. Make sure all fasteners are secure.
- **ALWAYS** replace defective components immediately and / or keep the equipment out of use until repair.
- **ALWAYS** position equipment on a level surface and away from water or ledges that could lead to accidental immersion or falls.
- Refer to additional warning notices posted on the equipment. If a product label or Owner's Manual should become lost, damaged or illegible, contact Customer Service at 800-847-0143 for replacement.

**SAVE THESE INSTRUCTIONS**

# ITEMS FOR ASSEMBLY

Parts are not shown to scale. Hardware drawings located on the insert inside each Hardware Kit.

ITEM NO.	ITEM NAME
<b>Stretch-and-Grip™ A-Frame Base Assembly</b>	
E61100	A-Frame
F51007	Angle Tether (x1) pre-assembled to A-Frame
F51008	EZ Angle Tether (x2, x3) pre-assembled to A-Frame
<b>FitSpine® Table Bed Assembly</b>	
EX1300	FitSpine® Table Bed
HK1010	FitSpine® Table Bed Hardware Kit
<b>Product Support</b>	
X1130	Owner's Manual (x1)
X1230	Owner's Manual (x2)
X1330	Owner's Manual (x3)
<div style="text-align: right; margin-right: 20px;">} <i>Pre-assembled to A-frame</i></div>	
<b>Handle Assembly</b>	
E61500	Stretch Assist™ Handles (2) (x1)
E61520	Stretch Max™ Handles (2) (x2, x3)
HK1008	Handle Assembly Hardware Kit

ITEM NO.	ITEM NAME
<b>Roller Hinge Assembly</b>	
F51064B	Roller Hinges (2) (x1)
TR1003B	Roller Hinges w/ Traction Handles (2) (x2, x3)
<b>Main Shaft Assembly</b>	
EX1600	with T-Pin Ankle Lock System (x1)
EX1630	with EZ-Reach™ Ankle Lock System (x2)
EX1620	with Deluxe EZ-Reach™ Ankle Lock System (x3)
<b>Tools Provided for Assembly</b>	
IA1149	5mm Allen Wrench (1)
EP1128A	6mm Allen Wrench (1)
F51088	Open-Ended Wrench (1)
<b>Optional Accessories</b>	
EX1350	Lumbar Bridge
EX1370	Acupressure Nodes
EX1810	Head Pillow

Stretch-and-Grip™ A-Frame Base Assembly with pre-assembled Angle Tether

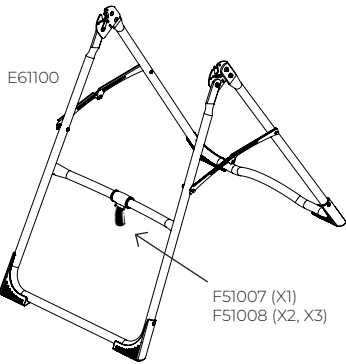

Handle Assembly Use with Handle Assembly Hardware Kit (HK1008)

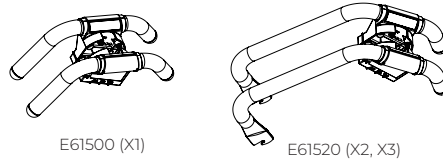

Roller Hinge Assembly

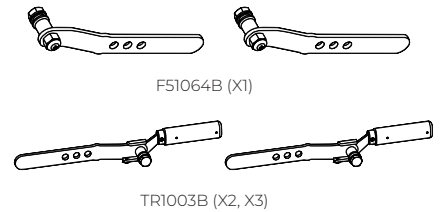

Main Shaft Assembly

T-Pin Ankle Lock System (X1 Model Only)

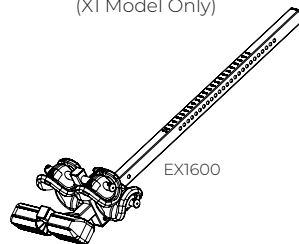

EZ-Reach™ Ankle Lock System (X2 Model Only)

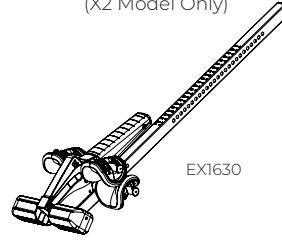

Deluxe EZ-Reach™ Ankle Lock System (X3 Model Only)

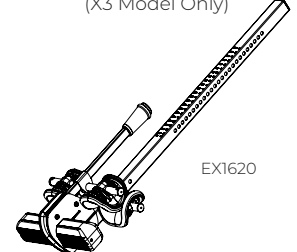

FitSpine® Table Bed Assembly Use with Table Bed Hardware Kit (HK1010)

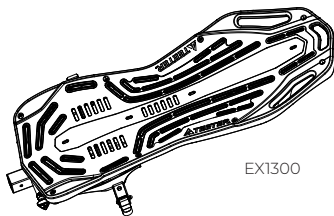

Tools Provided for Assembly



Included Accessories (Optional)

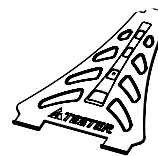

Lumbar Bridge EX1350

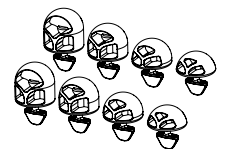

Acupressure Nodes EX1370



Head Pillow EX1810

Product Support

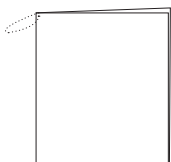

Owner's Manual  
X1130 (X1)  
X1230 (X2)  
X1330 (X3)

Items not shown to scale.

# A GUIDE TO YOUR INVERSION TABLE

Before reading further, study the drawing below to familiarize yourself with the important components of your Teeter Inversion Table.

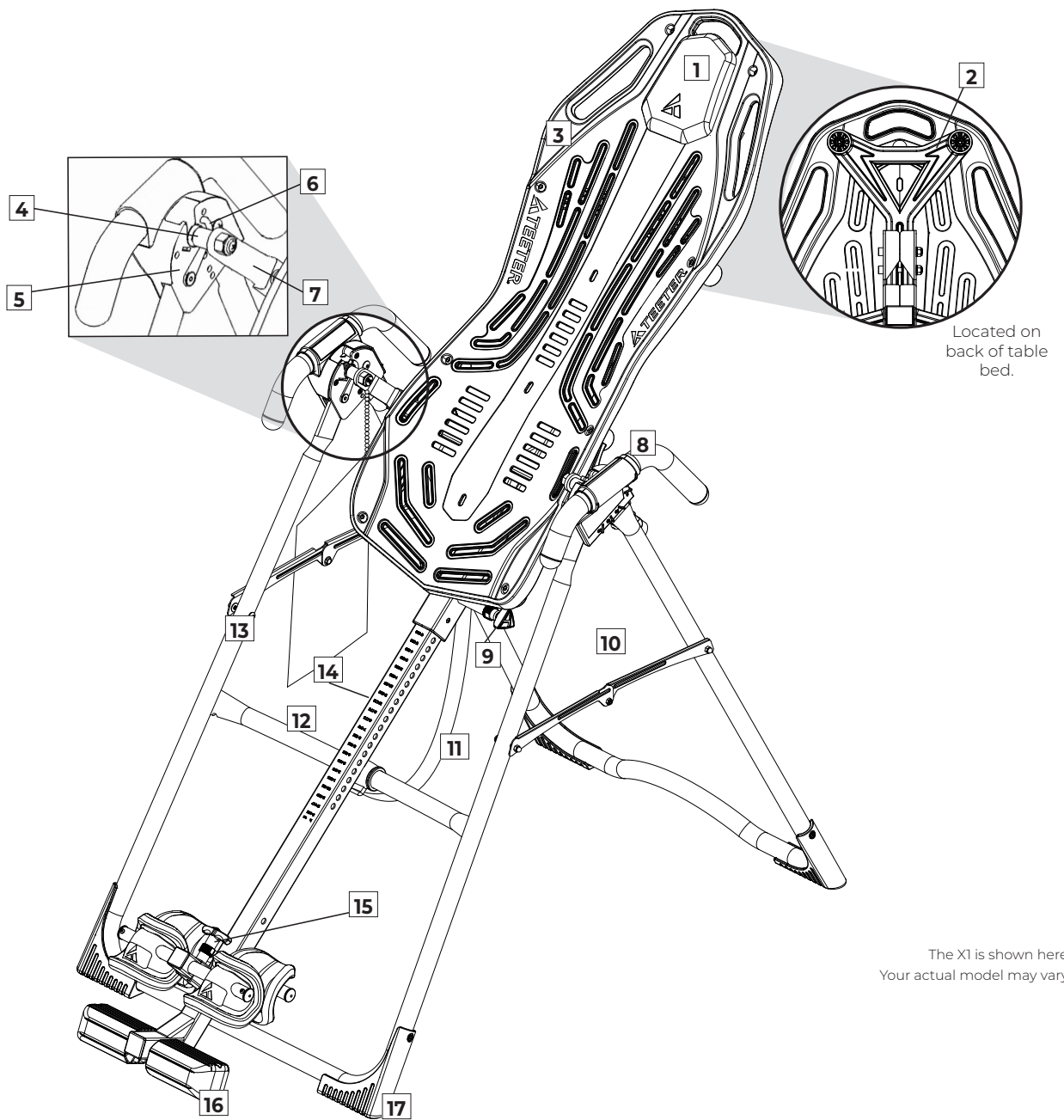

## Identifying Parts and Components

1	Head Pillow	7	3-Hole Roller Hinges	13	A-Frame
2	Upper Support Arms	8	Handles	14	Main Shaft
3	FitSpine Table Bed	9	Height-Selector Locking Pin	15	Ankle Lock System
4	Pivot Pins	10	Spreader Arms	16	Ankle Comfort Dial™
5	Hinge Plates	11	Angle Tether	17	Non-Skid Stability Feet
6	Self-Locking Hooks	12	Crossbar		

# SAFETY WARNING LABELS & PRODUCT SPECIFICATIONS

Important: Please review all labels and supporting materials before using your inversion table.

This drawing indicates the locations of the warning labels found on your product. If a label is missing, illegible or is removed, contact Teeter Customer Service to request a complimentary replacement label.

Note: Image and labels below not shown at actual size.

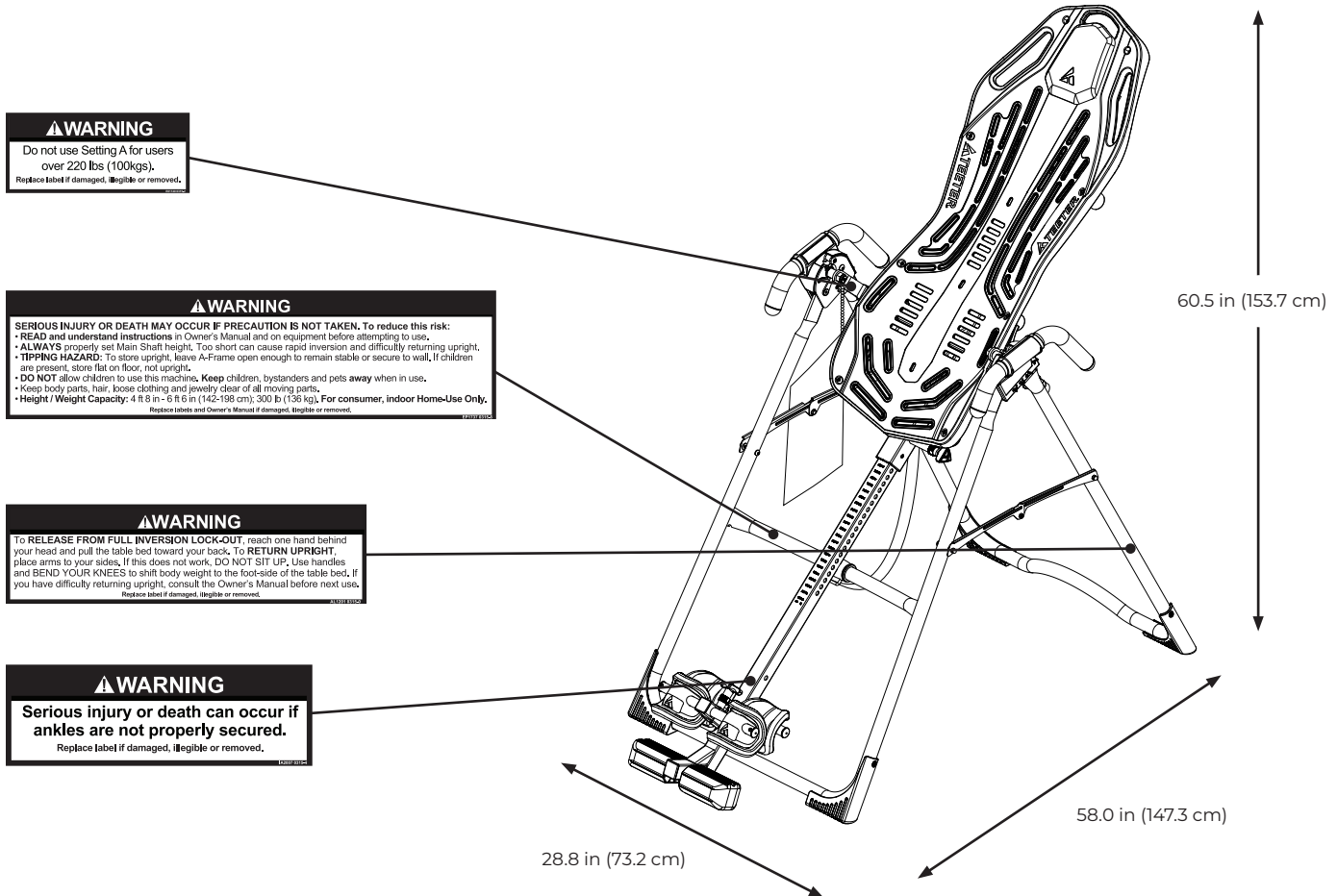

The X1 is shown here.  
Your actual model may vary.

Assembled Non-Use Dimensions: 58.0 (L) x 28.8 (W) x 60.5 in (H) (147.3 x 73.2 x 153.7 cm)  
Maximum In-Use Dimensions: 81.0 (L) x 28.8 (W) x 86.5 in (H) (205.7 x 73.2 x 219.7 cm)  
Storage Dimensions: 20.0 (L) x 28.8 (W) x 66.0 in (H) (50.8 x 73.2 x 167.6 cm)

Weight (approx.): X1: 59.3 lb (26.9 kg)  
X2: 64.4 lb (29.2 kg)  
X3: 65.8 lb (29.8 kg)

# LET'S GET STARTED

## Unpack and Prepare Your Workspace

- If possible, assemble the equipment at or near the space in which you intend to use it to avoid moving it later.
- Unpack all parts and support materials. Set aside packing materials and clear your work area.
- Locate the Hardware Kits packaged with the manuals. They are labeled to correspond with the assembly process.

## STEP 1

## FOR X1 MODELS ONLY: ASSEMBLE A-FRAME & HANDLES

**Figure 1:** On a level surface, position the A-Frame so that it is standing upright and the Stability Feet are on the ground.

Gently push down on the Spreader Arms to ensure they are fully open and in the “locked” position.

Look for temporary circular assembly assistance labels on the A-Frame. **RIGHT, LEFT, FRONT,** and **REAR** indicate your position while using the equipment, not facing it. These labels can be removed easily upon completion of assembly.

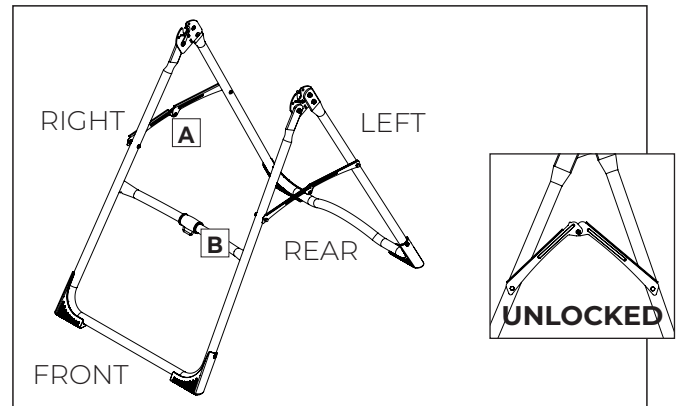

A - Spreader Arms B - Crossbar

Figure 1

*Locate the Handle Assembly Hardware Kit (HK1008).*

**Figure 2:** Determine the left or right handles, marked with an embossed L / R on the inside of the black plastic part of each handle.

Align the black plastic part of the corresponding handle (left / right) over the outside edge of the Hinge Plate on the A-Frame.

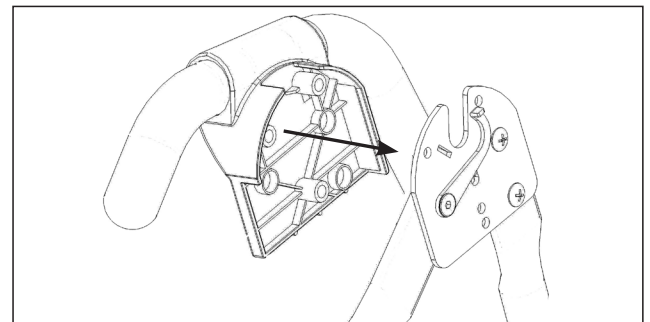

Figure 2

**Figure 3:** Insert and loosely hand-tighten three of the Allen Head Bolts through the Hinge Plate into the handle.

Repeat with other handle. Tighten all fasteners with the 5mm Allen Wrench provided, being careful not to over-tighten.

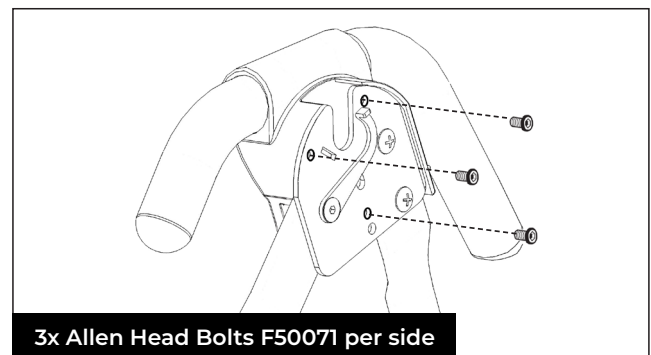

Figure 3

# STEP 1

## FOR X2 & X3 MODELS ONLY: ASSEMBLE A-FRAME & HANDLES

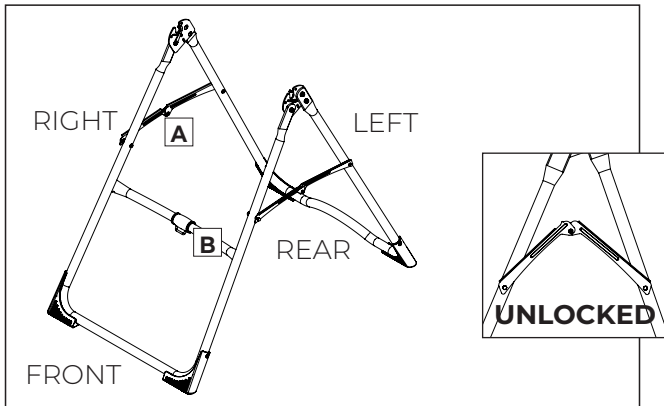

Figure 4      **A** - Spreader Arms   **B** - Crossbar

**Figure 4:** On a level surface, position the A-Frame so that it is standing upright and the Stability Feet are on the ground.

Gently push down on the Spreader Arms to ensure they are fully open and in the “locked” position.

Look for temporary circular assembly assistance labels on the A-Frame. **RIGHT, LEFT, FRONT, and REAR** indicate your position while using the equipment, not facing it. These labels can be removed easily upon completion of assembly.

*Locate the Handle Assembly Hardware Kit (HK1008).*

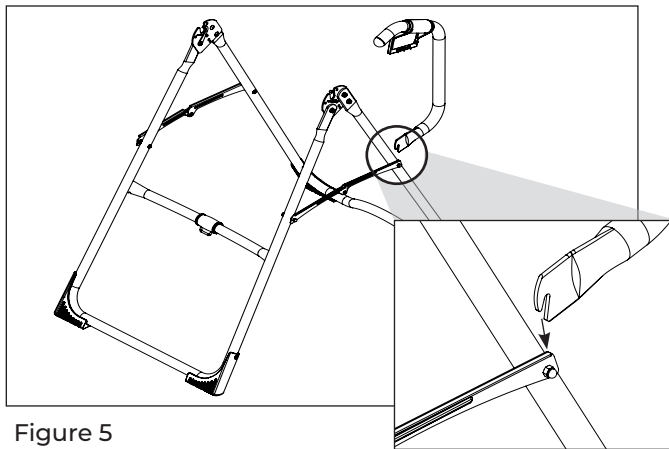

Figure 5

Figure 5a

**Figure 5 & 5a:** Determine the left or right handles, marked with an embossed L / R on the inside of the black plastic part of each handle.

Position the lower handle portion of the corresponding handle (left / right) at the rear junction of the A-frame leg and Spreader Arm. The Lower Handle Bolt with Spacer has been assembled loosely so that you will be able to seat the U-shaped portion of the lower handle over the Spacer in between the Spreader Arm and the A-frame leg. Do not tighten the bolt yet.

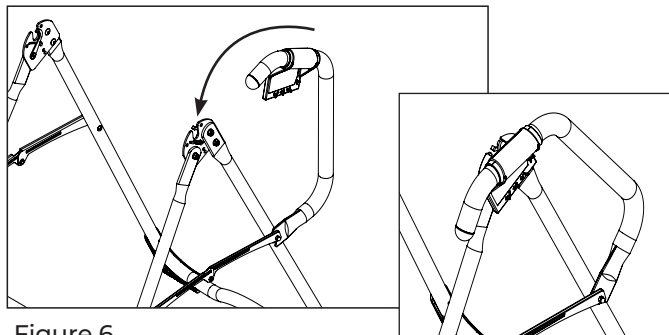

Figure 6

Figure 6a

**Figure 6 & 6a:** Keeping the lower handle portion seated onto the Spacer, align the upper handle portion's black plastic part over the outside edge of the Hinge Plate on the A-Frame.

**Figure 7:** Insert and loosely hand-tighten three of the Allen Head Bolts through the Hinge Plate into the handle.

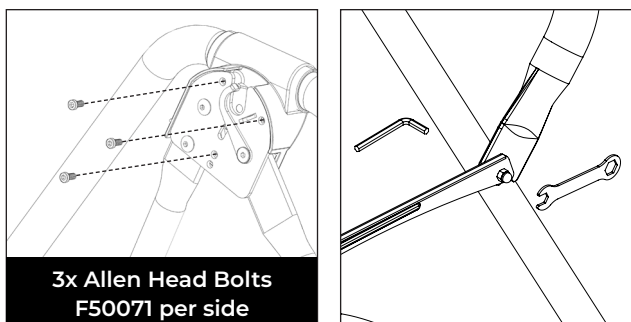

Figure 7

Figure 8

**Figure 8:** Now tighten the Lower Handle Bolt using the 5mm Allen Wrench and Open Wrench provided, ensuring that it is fully secured but not over-tightened.

Finally, tighten the Allen Head Bolts for the upper handle using the 5mm Allen Wrench provided.

Repeat these steps on the other handle.



## STEP 2

# FOR ALL MODELS: ASSEMBLE TABLE BED

Locate the Table Bed Assembly Hardware Kit (HK1010).

**Figure 9:** Place the Table Bed face down on the floor and push down on the Support Beam, so the two holes align evenly with the holes at the base of the Upper Support Arms. You may have to exert extra pressure to ensure that the Support Beam slides over the rubber spacers.

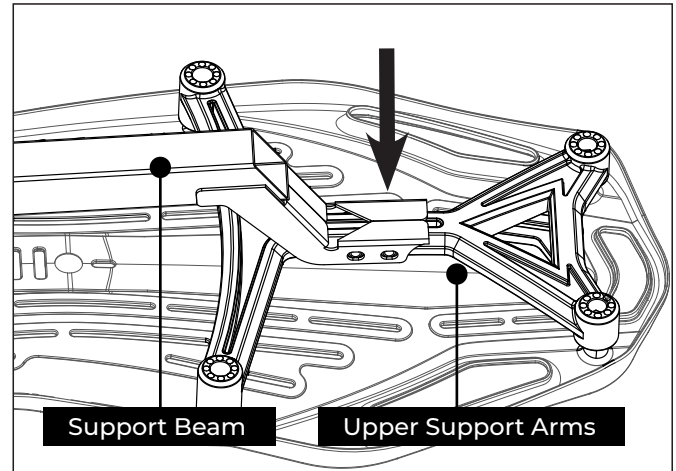

Figure 9

**Figure 10:** Insert the two Bolts into the open holes.

Thread a Washer and Nut onto each Bolt and hand-tighten.

Using the 6mm Allen Wrench to steady the bolts, tighten the Nuts onto the Bolts with the 10/13mm Open-Ended Wrench.

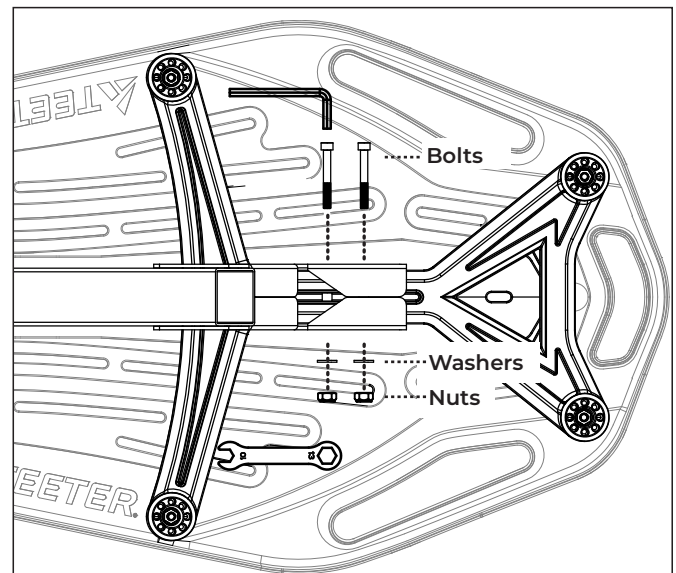
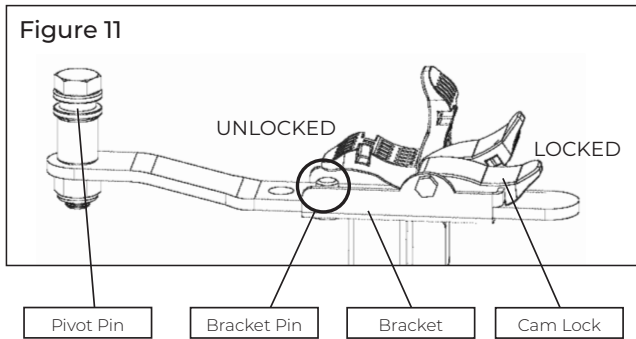

Figure 10

# STEP 3

## FOR ALL MODELS: ASSEMBLE ROLLER HINGES TO TABLE BED



**Figure 11:** Familiarize yourself with the 3-Hole Roller Hinge and Cam Lock terms.

### ⚠️ WARNING

NEVER disassemble the Roller Hinge Pivot Pin. ALWAYS insert the 3-Hole Roller Hinge (with the Pivot Pin on top and facing out) in the same direction as the arrow label located inside of the Cam Lock for proper assembly.

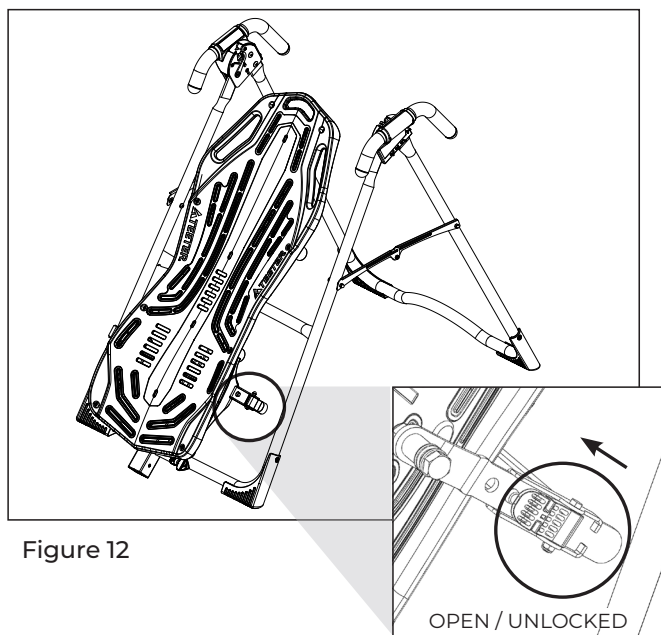

**Figure 12:** For ease of assembly, rest the Table Bed against the Crossbar at the front of the A-Frame.

**Figure 12a:** On one side of the Table Bed, lift and hold the Cam Lock up all the way to unlock.

In your other hand, hold one Roller Hinge near the Pivot Pin. With the Pivot Pin facing out (away from the Table Bed), slide the bottom of the Roller Hinge between the Cam Lock and the Bracket in the same direction as the arrow label located inside of the Cam Lock.

**TIP:** Make sure that the Cam Lock is completely open when inserting the Roller Hinge, otherwise assembly will be more difficult.

Figure 12a

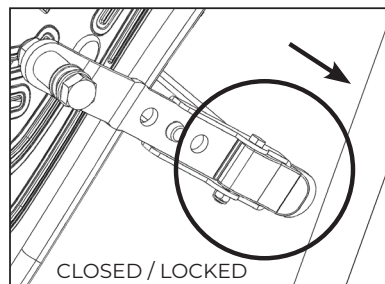

**Figure 13:** Engage one of the holes in the Roller Hinge over the Bracket Pin. Push down on the Cam Lock to lock it and secure the Roller Hinge.

Repeat on other side. Make sure the Roller Hinges are in the same hole setting on both sides.

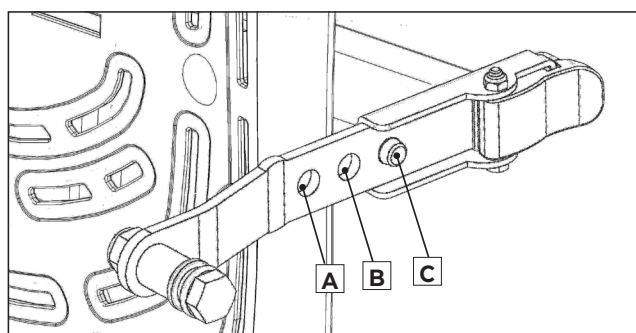

**Figure 14:** This figure shows the Roller Hinge installed correctly, with the Bracket Pin engaged in Setting C.

**NOTE:** Refer to the Owner's Manual for an explanation of the hole settings. If you are unsure, use Setting C to start.

The X1 is shown here. Your actual model may vary.

# STEP 4

## FOR ALL MODELS: ASSEMBLE TABLE BED TO A-FRAME

**Figure 15:** Face the front of the A-Frame where the Crossbar is located. Grasp both Roller Hinges, right above the Cam Lock, and lift the Table Bed. Allow the top of the Table Bed to rotate toward the floor, so that the back of the Table Bed is now facing you and the top of the Table Bed is in front of the Crossbar.

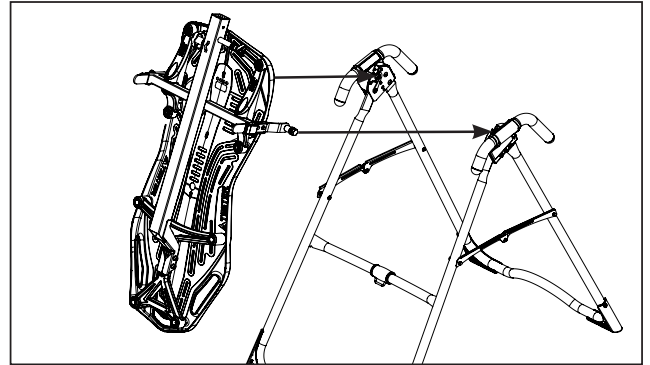

Figure 15

**Figure 16:** Lower each Roller Hinge Pivot Pin into the A-Frame hinge plates, one side at a time. The Self-Locking Hooks will open to allow the Pivot Pin into the Hinge Plate slot, then automatically snap closed over the Pivot Pin.

TIP: You may need to push outward on the Hinge Plate in order for the second Pivot Pin to lock in place.

**Figure 17a & 17b:** Make sure that each Pivot Pin is seated at the base of the slot in the Hinge Plates, and that the Self-Locking Hooks have closed over both Pivot Pins.

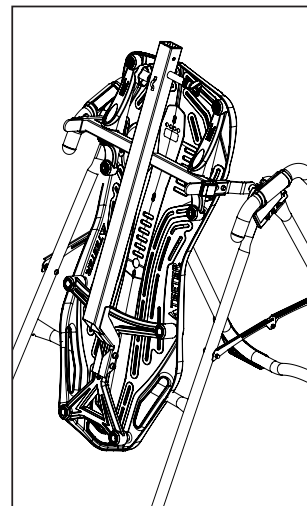

Figure 16

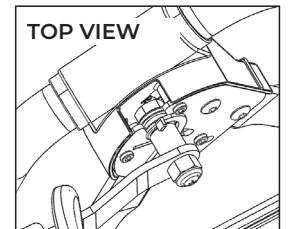

Figure 17a

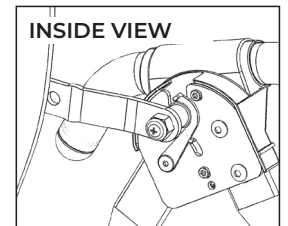

Figure 17b

### **⚠ WARNING**

Failure of the Self-Locking Hooks to close over both Roller Hinge Pivot Pins is an indication of improper assembly and if not corrected could result in serious injury or death!

**Figure 18:** Rotate the Table Bed so that it is facing up. Ensure that it rotates smoothly. See also Image A on Page 11 to ensure correct assembly.

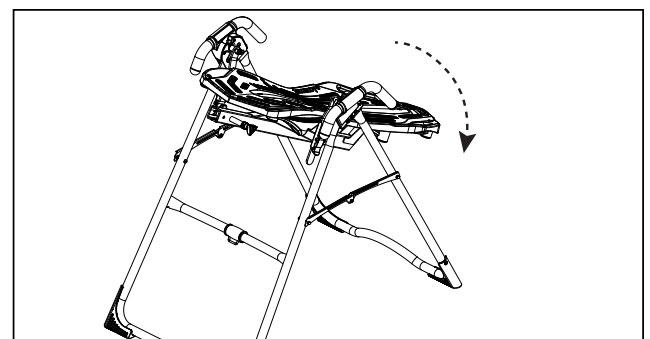

Figure 18

The X1 is shown here. Your actual model may vary.

# STEP 5

## FOR ALL MODELS: ASSEMBLE MAIN SHAFT TO TABLE BED

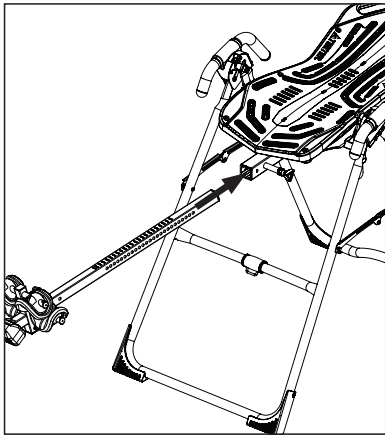

Figure 19

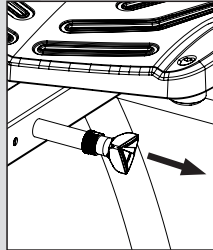

Figure 19a

**Figure 19:** Stand on the LEFT side of the A-Frame, holding the Main Shaft with the height markings facing up. Begin to slide the end of the Main Shaft into the Main Shaft Housing at the base of the Table Bed.

**Figure 19a:** With your right hand, pull out the Height-Selector Locking Pin and slide the Main Shaft in further. Release in the desired height setting. Refer to the Owner's Manual for more information on selecting your height setting.

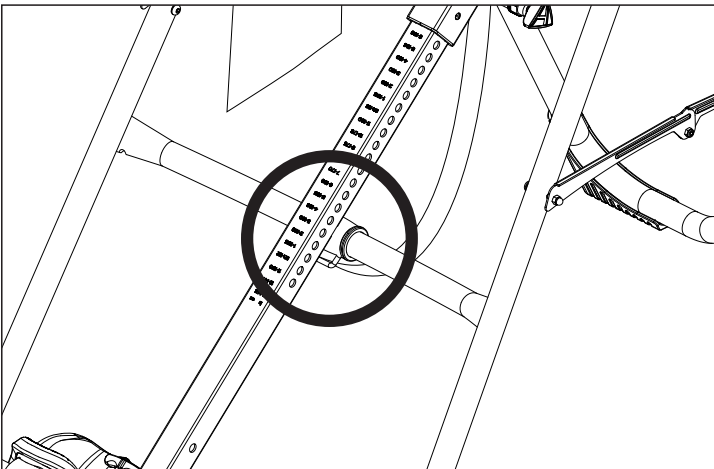

Figure 20

**Figure 20:** The Main Shaft MUST REST against the Crossbar of the A-Frame.

**IMPORTANT:** The Crossbar prevents the Table Bed from rotating forward when the user steps on the Ankle Comfort Dial. If the Main Shaft does not rest on the Crossbar as shown here, then the Table Bed has been assembled backwards onto the A-Frame. This must be corrected before use.

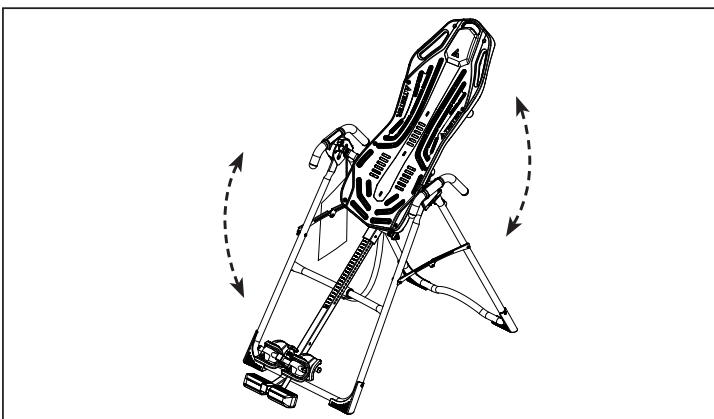

Figure 21

**Figure 21:** Test the inversion table by hand for smooth and steady rotation and ensure that all fasteners are secure.

The X1 is shown here. Your actual model may vary.

# MISASSEMBLY CHECK

## **WARNING**

If your Teeter Inversion Table looks like either of these images, your inversion table has been misassembled and is unfit for use. Improper assembly could result in serious injury or death!

### **Image A**

Go back to Step 3 for instruction.

Demonstrates that the Roller Hinges have been assembled upside down into the Table Bed and must be corrected.

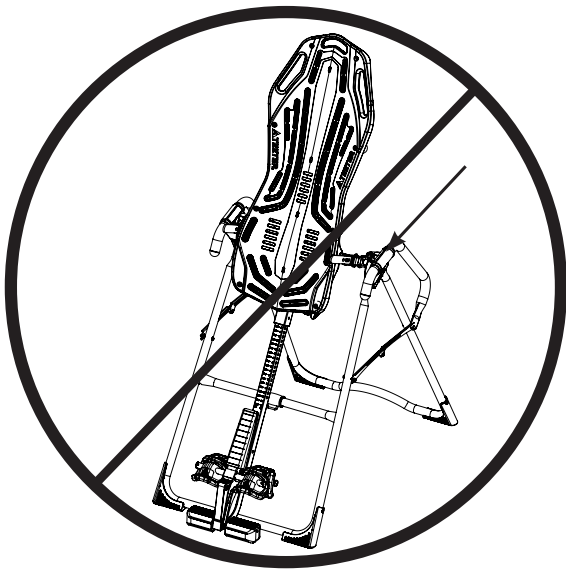

### **Image B**

Go back to Step 4 for instruction.

Demonstrates that the Table Bed has been assembled into the A-Frame backwards so the Main Shaft is not resting on the Crossbar and must be corrected.

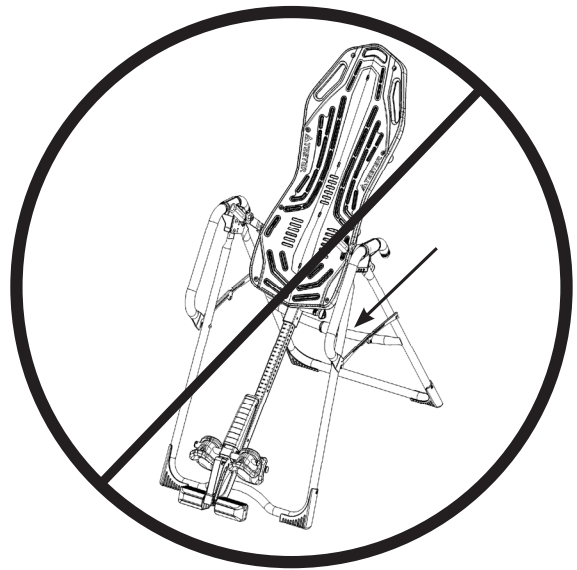

## STEP 6

# FOR ALL MODELS: ATTACH ANGLE TETHER & HEAD PILLOW

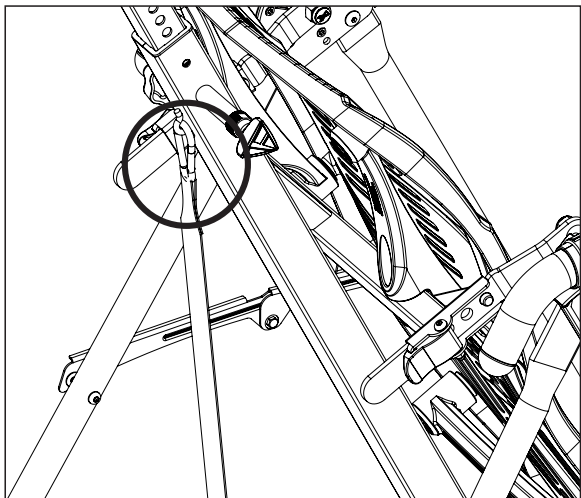

Figure 22

### Attach Angle Tether

The tether will come pre-assembled to the A-Frame.

**Figure 22:** Unfold the adjustable tether and clip it to the U-Bar on the underside of the Table Bed.

Slide the buckle to lengthen or shorten the strap depending on your desired maximum angle of inversion.

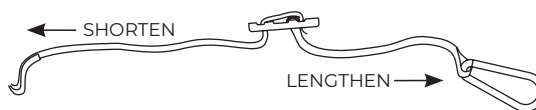

### EZ-Angle Tether Accessory

Some models may come with the EZ-Angle Tether, embroidered with color-coded angle markers at 20° (GREEN), 40° (ORANGE), or 60° (RED). Simply slide the buckle so its center aligns with your desired color setting.

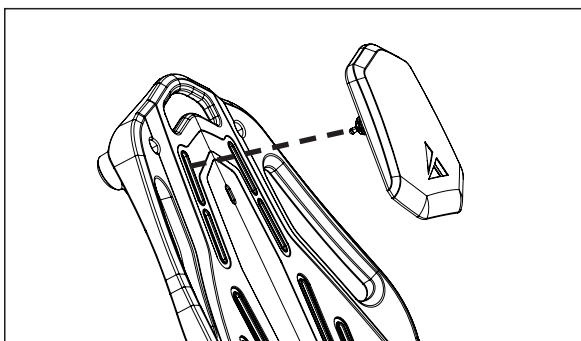

Figure 23

### Attach Head Pillow

**Figure 23:** Locate the slots at the top of the Table Bed just beneath the Handhold as shown.

Insert the two pointed ends on the back of the Head Pillow into the slot of the Table Bed and pull through from the back of the Table Bed to secure the pillow into position.

## STEP 7

# ATTACH LUMBAR BRIDGE (OPTIONAL)

The Lumbar Bridge provides even deeper decompression and improved alignment benefits. Personalize the intensity and target zone of the Lumbar Bridge by adjusting the height and position of the arch within the slots on the Table Bed so it fits comfortably at the small of your back.

Stabilize the inversion table to prevent rotation during assembly.

Position the bridge with the Teeter logo at the base and facing towards you.

**Figure 24:** First, insert the bottom two notches of the bridge into the desired horizontal slots on the lower portion of the Table Bed.



Figure 24

**Figure 25:** Bend the bridge to the arch height you desire and insert the one top notch into the corresponding slot on the upper portion of the Table Bed.

Modify the positioning and arch height as needed.

**NOTE:** Long-term storage of the Lumbar Bridge in a high arch setting may result in distortion of the shape and ability of the bridge to move to lower arch settings. Store in its flat position when not in use.



Figure 25

## Use Instructions

Use of the Lumbar Bridge may impact the rotation of the table. Set the Angle Tether to a moderate inversion angle and use a spotter until you are able to find the correct balance settings and are comfortable with the operation of the table.

Start in a lower level arch setting and work your way up. If you feel any discomfort, lower the setting until you are comfortable or discontinue use.

**Figure 26:** The Lumbar Bridge works between intermediate to moderate inversion. Full inversion moves the body away from the table bed and will reduce the effectiveness of the bridge.



Figure 26

## STEP 8

# ATTACH ACUPRESSURE NODES (OPTIONAL)

Personalize the intensity and target zone of the Acupressure Nodes by positioning the varying sizes along the FitSpine® bed tracks as desired.



Figure 27

**Figure 27:** Determine your desired node position along the table bed. Unscrew the black backing from the node and insert the backing into the slot from the rear of the bed so the threads are visible from the front.

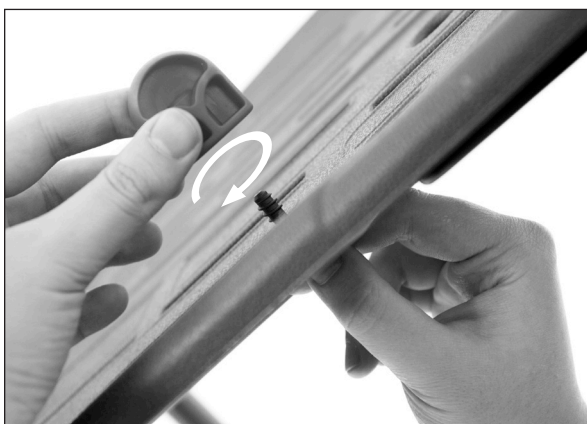

Figure 28

**Figure 28:** Twist the node clockwise into the backing to secure. Do not overtighten to avoid damaging the node.

Repeat, as desired, with additional nodes.

To shift node placement within a track, simply loosen the backing and slide the node in the slot.



Figure 29

## Use Instructions

Start with the smaller nodes and work your way up to the larger ones. The ideal placement of the nodes depends on where your muscle tension points align with the slots in the table bed.

The pressure of the nodes will vary as the table rotates up or down. The nodes work best between intermediate to moderate inversion (20-45 degrees). Full inversion moves the body away from the table bed and will reduce the effectiveness of the nodes. While inverted, stay at a static incline to maintain a steady pressure, or oscillate (move between different angles of inversion) for a massaging action.

Use of the nodes may cause muscle soreness. If you feel any discomfort, decrease or discontinue use.



# BEFORE INVERTING

## Ensure Owner's Manual is Attached

The Owner's Manual contains important information on how to use your Teeter Inversion Table, including how to personalize the user settings, properly secure and release the Ankle Lock System, and test and adjust the rotation control.

**Figure 30 & 30a:** If the Owner's Manual is not already attached, secure the chain to the A-Frame through the designated hole in the Hinge Plate. Allow the Owner's Manual to hang freely on the outside of the A-Frame Spreader Arms so it doesn't interfere with the rotation of the Table Bed.

**IMPORTANT:** Once attached to the A-Frame, DO NOT remove the Owner's Manual. It should remain permanently attached to your inversion table to serve as a reference for all users in regard to proper adjustment and use of the equipment.

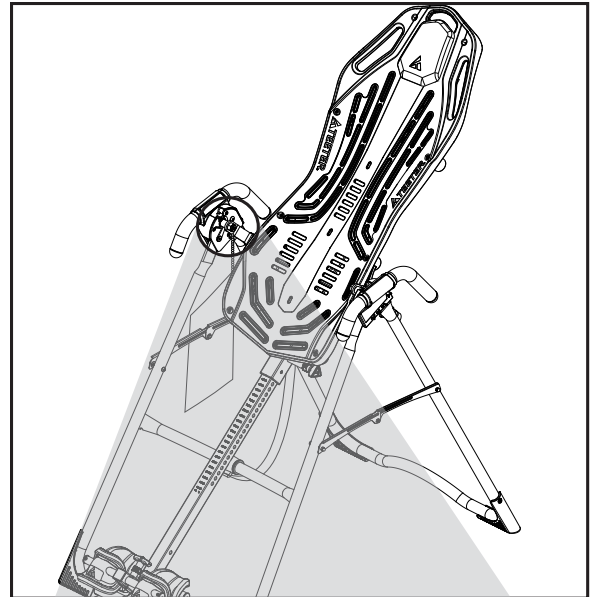

Figure 30

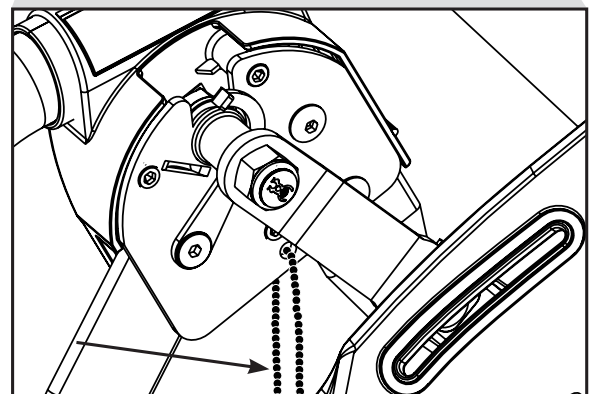

Figure 30a

## **⚠️ WARNING**

Read the Owner's Manual thoroughly before using your Teeter Inversion Table. Improper settings could result in serious injury or death!

## Watch the Getting Started Videos

The Getting Started Video Portal is a helpful supplement to the Owner's Manual, with easy-to-follow instructions on user settings, how to invert, storage and maintenance, and even stretching and exercises you can do with your Teeter. **Access via [teeter.com/videos](https://teeter.com/videos) and search your FitSpine Model now!**

The Teeter warranty set forth below and on Teeter's website applies to US and Canadian customers only. For international customers, please consult your local distributor for warranty information which will vary depending on country.



During the period starting with the day of retail purchase and continuing for five (5) years, Teeter extends to the owner a repair and replacement warranty against manufacturing defects in materials, workmanship, fabrics and padding. Teeter will repair or replace any such defect and will pay the costs of all parts, labor and transportation. If a repair or replacement is not commercially practical or cannot timely be made, then Teeter will, at the original Purchaser's option, replace with a comparable product or refund the purchase price.

Handling and transportation costs related to product warranty service only are covered by this warranty. This warranty does not cover damage resulting from improper handling, assembly, or installation, repairs made by others, accident, misuse, or abuse. Under no circumstances shall Teeter, or any other party involved in the sale of this product, have any liability for incidental or consequential damage arising from breach of an express or implied warranty on any Teeter product.

**EXCEPT AS SET FORTH ABOVE, NO WARRANTY IS GIVEN WITH RESPECT TO ANY TEETER PRODUCT, AND ALL EXPRESS WARRANTIES ARE DISCLAIMED.** This warranty shall be governed by the laws of the State of Washington, USA. To the extent this warranty is found not to be enforceable, it shall be deemed revised to the extent necessary to make it enforceable. This warranty and any controversy or claim arising out of this warranty or its interpretation shall be governed by the laws of the State of Washington, USA. Any controversy or claim arising out of or relating to this warranty, its interpretation, or any alleged breach thereof, which cannot be amicably settled between Teeter and the owner within sixty (60) days of written notice by the aggrieved party to the other, shall be finally settled by arbitration submitted to three (3) arbitrators selected from the panels of the arbitrators of the American Arbitration Association located closest to Teeter's principal place of business.

Some states do not allow the exclusion of incidental or consequential damage from a warranty, so the above limitation or exclusion may not apply to you. Some states do not allow limitations on how long an implied warranty lasts, so the above limitation may not apply to you. This warranty gives you specific legal rights, and you may also have other rights which may vary from state to state.

## HOW TO SUBMIT YOUR REGISTRATION:

### Step 1

Fill out this information for your own records.

### Step 2

Go online to [teeter.com](http://teeter.com) to register your warranty.

\_\_\_\_\_

Date of Purchase

\_\_\_\_\_

Product & Model

\_\_\_\_\_

Dealer Name

\_\_\_\_\_

Serial No. (located on the back of the Table Bed)



## FREE DIGITAL GUIDE AVAILABLE!

Maximize your Time on your Teeter Inversion Table

Go to [teeter.com](http://teeter.com) and register your warranty to gain **FREE** access to this downloadable exercise guide.

If you are unable to go online, you can request a warranty card to be mailed to you by calling Customer Service at 800-847-0143.

Please **DO NOT** mail this to Teeter.





### Better Back™ Foam Rollers

Prepare the body for movement, accelerate recovery, minimize muscular imbalances, and improve overall flexibility with the Teeter collection of textured Foam Rollers.



### Neck Relax & Restore Duo™

Provides support of the upper neck/cervical spine for self-administered suboccipital release, a technique to reduce tension in the supporting muscles.



### Comfort Cushion

The soft, padded surface takes Teeter comfort to the next level, providing a plush surface that minimizes pressure points for superior comfort.



### Posture Restore

Promotes additional posture correction by stretching the muscles that have shortened and adapted to a hunched posture, helping to open the chest, shoulders, and hips while gently decompressing and elongating the spine.



### Inversion Program Mat

Enhance your inversion experience with 24 illustrated stretches and exercises right at your fingertips. Provides non-skid protection for hard floors. 36" x 60".

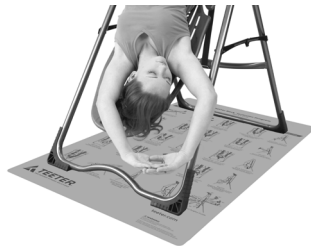

### FreeStep® Recumbent Cross Trainer

Zero-impact cardio and strength! The ONLY home-use machine with patented smooth-stride technology found in high-end seated physiotherapy steppers.



### Power10™ Elliptical Rower

Torch more calories and enhance muscle definition with one revolutionary rower. The patented elliptical path offers bi-directional resistance so you can engage more muscles with every workout.



### FitForm™ Cable Trainer

Total body strengthening in one small package! Work your arms, legs and core with micro-adjusting resistance up to 65 lb.



If you have any trouble assembling the equipment, or questions about its use, please contact customer service.

Phone: 800-847-0143  
Email: [info@teeter.com](mailto:info@teeter.com)

Teeter  
9713 233rd Avenue East Ste A  
Bonney Lake, WA 98391  
Toll Free: 800-847-0143  
Fax: 800-847-0188  
[teeter.com](http://teeter.com) | [info@teeter.com](mailto:info@teeter.com)



This product is Listed by Underwriters Laboratories Inc. Representative samples of this product have been evaluated by UL and meet applicable safety standards.

Any modification to this device will void the UL Listing.



Medical Device Safety Service  
GmbH  
Schiffgraben 41  
30175 Hannover  
Germany  
Tel. +49 511 62628630



Teeter Decompression Devices are multiple user, reusable devices for home use, intended to provide traction to the spine while stretching the para-spinal muscles and soft tissues. The devices provide non-powered traction and are meant for use by adults.

Use of the Teeter Decompression Devices is indicated for the following conditions: back pain, muscle tension, degenerative disc disease, spinal degenerative joint disease, spinal stenosis, herniated disc, spinal curvature due to tight muscles, sciatica, muscle spasm, and facet syndrome.